



GOES

TERROX

**READ THIS
MANUAL
CAREFULLY**

It contains important
safety information

Make sure operator holds a valid driver license.
Make sure passengers wear an approved helmet and
protective gear, and securely grasp hand holds and plant
feet firmly on footrests when seated.

TABLE OF CONTENTS

Signal Words	5
Introduction.....	9
Vehicle Identification Number.....	9
Specification.....	10
Operator Safety	14
Age Restrictions	14
Know Your Vehicle	14
Equipment Modifications	15
Avoid Burns from Hot Parts.....	16
Pulling a Trailer	16
Safety Training	17
Hazardous Operation Warnings	17
Safe Riding Gear.....	41
Safety Decals and Locations.....	42
Features and Controls	46
Left Hand Controls	46
Right Hand Controls.....	49
Foot Controls.....	54
Vehicle Features	55

Winch Operation	64
CVT System	75
Engine Braking System (EBS)	76
How To Avoid CVT Drive Belt and Component Failure	77
Dashboard Indicators and Operation	79
Operation of Your Vehicle	85
Break-In Period	85
Pre-Ride Inspection.....	87
Starting the Engine.....	88
Gear Selector Operation	90
Hauling and Towing Cargo	93
Load Distribution	95
Driving Safely	101
Maintenance	117
Severe Use Definition	117
Periodic Maintenance Schedule and Icon Key.....	118
Pre-Ride Maintenance Checklist.....	120
Break-In Maintenance Checklist	122
Periodic Maintenance Schedule.....	124
Maintenance Procedures	131

FOREWORD

Lights.....	161
Cleaning and Storage.....	165
Transporting the Vehicle.....	169
Vehicle Issue Diagnosis.....	170
Engine doesn’ t turn over	170
Engine pings or knocks	170
Engine stops or loses power	171
Engine turns over, Fails to start.....	172
Engine backfires.....	173
Engine runs irregularly, stalls or misfires.....	173
EFI Malfunction Indicator Light.....	177
EPS Malfunction Indicator Light	178
Declaration	181
Declaration of Drivers exposure to noise level	181
Declaration of Vibration declaration	182

FOREWORD

Signal Words

A signal word calls attention to a safety message or messages, a property damage message or messages, and designates a degree or level of hazard seriousness. The standard signal words in this manual are WARNING, CAUTION and NOTE or NOTICE.

Familiarize yourself with all laws and regulations concerning the operation of this vehicle in your area. We strongly advise you to strictly follow the recommended maintenance program outlined in your owner's manual. This preventive maintenance program is designed to ensure that all critical components on your vehicle are thoroughly inspected at specific intervals.

The following signal words and symbols appear throughout this manual and on your vehicle. Your safety is involved when these words and symbols are used. Become familiar with their meanings before reading the manual.

WARNING

This safety alert and icon indicates a potential hazard that may result in serious injury or death.

CAUTION

This safety alert and icon indicates a potential hazard that may result in minor or moderate personal injury and/or damage to the vehicle.

CAUTION

This safety alert without an icon indicates a situation that may result in damage to the vehicle.

NOTE or NOTICE

A note or notice will alert you to important information or instructions

FOREWORD WARNING

Improper vehicle use can result in SEVERE INJURY or DEATH

NEVER Operate:

- Without first viewing owner's manual and quick start guide.
- Carrying more passengers than the rated passenger capacity.
- Use ALCOHOL or DRUGS before or while driving this vehicle.

ALWAYS:

- Keep hands and feet inside vehicle.
- Reduce speed and use extra caution when carrying a passenger.
- Operate slowly in reverse-avoid sharp turns or sudden braking.
- Make sure passenger reads and understands all safety labels.
- Watch for branches or other hazards that could enter vehicle.
- Use safety belt during operation.

**Locate and Read Owner's manual
Follow all INSTRUCTIONS and WARNINGS.**

FOREWORD
⚠️ WARNING FOR TYPE VEHICLES

(2-person vehicle)

Improper vehicle use can result in SEVERE INJURY or DEATH



**ALWAYS
USE AN
APPROVED
HELMET AND
PROTECTIVE
GEAR**



**NEVER
CARRY MORE
THAN ONE
PASSENGER**



**NEVER
USE WITH
DRUGS OR
ALCOHOL**

FOREWORD
READ THE OWNER'S MANUAL

FOLLOW ALL INSTRUCTIONS AND WARNINGS

 WARNING

Read, understand, and follow all of the instructions and safety precautions in this manual and on all product labels. Failure to follow the safety precautions could result in serious injury or death.

 WARNING

The engine exhaust gas from this product contains CO, which is deadly gas and could cause headache, giddy, disgusting or lose consciousness, even death.

 WARNING

Engine box cover, brake disc and muffler exhaust pipe will be hot easily after long period usage. Avoid being burned by those parts.

INTRODUCTION

Introduction

Vehicle Identification Number

Record your Vehicle's identification numbers in the spaces provided, Remove the spare key and store in a safe place. Your key can be duplicated only by mating key blank with one of your existing keys. So if both keys are lost, the complete lock kits have to be replaced.

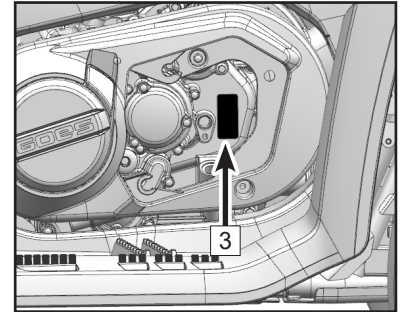
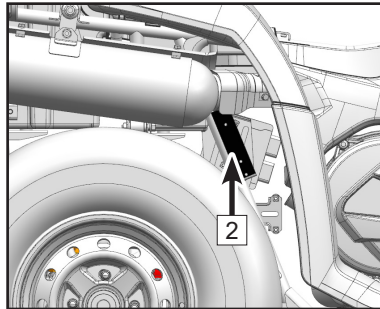
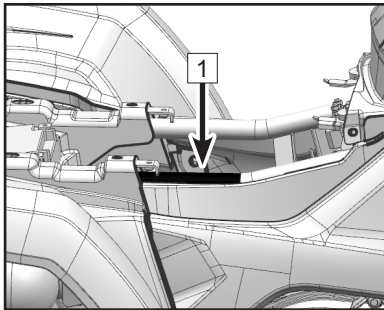

1 Vehicle identification number: _____

2 Vehicle model number: _____

3 Engine serial number: _____

INTRODUCTION

Specification

Item	Specification			
	TERROX 400S	TERROX 500S	TERROX 400L	TERROX 500L
Overall Length	2190 mm	2390 mm	2190 mm	2390 mm
Overall Width	1100 mm	1100 mm	1100 mm	1100 mm
Overall Height	1200 mm	1435 mm	1200 mm	1435 mm
Wheel Base	1260 mm	1460 mm	1260 mm	1460 mm
Minimum Ground Clearance	240 mm	250 mm	250 mm	250 mm
Min. Turning Radius	3750 mm	4250 mm	3750 mm	4250 mm
Basic Weight	358 kg	382 kg	358 kg	382 kg
Engine Model and Type	191Q	191R	191Q	191R
Engine Model and Type(ABS)	/	/	191Q-D	191R-J
Type	Water - cooling / 4stroke ,SOHC			
Bore X Stroke	91 mm×61.5 mm	91 mm×76.2 mm	91 mm×61.5 mm	91 mm×76.2 mm
Displacement	400mL	495mL	400mL	495mL
Compression Ratio	10.3 : 1			
Starting Type	Electric start			
Lubrication Type	Splashed by pressure			

INTRODUCTION

Item	Specification
Engine oil: Type	SAE 5W-40 /SAE 10W-40 /SAE 15W-40
Engine oil volume Capacity Change / Oil Filter	2.96 qt (2.8 L)
Rear gear case oil	
Type	SAE80W/90 GL-5
Volume	0.25 L
Front gear case oil:	
Type	SAE80W/90 GL-5
Volume	0.2 L
Air filter	Dry-spongy filter element
Maximum speed	T3a
	T3b

INTRODUCTION

Item		Specification	
Fuel type		95(RON) or E10	
Fuel tank capacity		15 L	
Fuel reverse amount		3.0 L	
Spark plug:		DCPR8E (NGK)	
Type		0.8 mm ~ 9 mm	
Spark plug gap			
	Clutch type	Wet and centrifugal automatic	
	Transmission Type	C(continuous variable transmission)(CVT)	
	Gear shift/order	Manually/L-H-N-R-P	
	Final drive ratio	3.667	
	Gear ratio	8.698~38.929	8.698~38.929
		16.322~73.043	16.322~73.043
13.344~59.721		13.344~59.721	
Chassis		Steel tube	
Frame		9°52'	
Caster angle		26.5 mm	
Kingpin offset			

INTRODUCTION

Item	Specification
Shock absorber:	
Front shock absorber	Coil spring/Oil damper
Rear shock absorber	Coil spring/Oil damper
Wheel travel:	
Front wheel travel	180mm
Rear wheel travel	180mm
Electric system	ECU
Ignition	A.C magneto
Flywheel storage battery	12V 30A
Light system	
Headlight type	HS1 12V 35/35W
Front Turn light	LED
Front position light	LED
Rear Turn light	12V R10W
Tail light/Brake light	LED
Registration board light	12V 5W W5W
Dashboard indicator light	LED

OPERATOR SAFETY

Operator Safety

⚠️ WARNING

Failure to heed the warnings contained in this manual can result in serious injury or death. An Vehicle is not a toy and can be hazardous to operate. This vehicle handles differently from other vehicles, such as motorcycles and cars. A collision or rollover can occur quickly , even during routine maneuvers, like turning, or over obstacles, if you fail to take proper precautions.

Read this owner's manual. Understand all safety warnings, precautions and operating procedures before operating an Vehicle.

Age Restrictions

This vehicle is an ADULT Vehicle ONLY. Operation is prohibited for anyone under the age of 16.

Know Your Vehicle

As the operator of the vehicle, you are responsible for your personal safety, the safety of others, and the protection of our environment. Read and understand your owner's manual, which includes valuable information about all aspects of your vehicle, including safe operating procedures.

NOTE:

The passenger seat only allows the transport of passengers on public roads and not during field operations, it shall not be used during field operations.

OPERATOR SAFETY

Equipment Modifications

We are concerned with the safety of our customers and for the general public. Therefore, we strongly recommend that consumers do not install on an Vehicle any equipment that may increase the speed or power of the vehicle, or make any other modifications to the vehicle for these purposes. Any modifications to the original equipment of the vehicle create a substantial safety hazard and increase the risk of body injury. The warranty on your Vehicle is terminated if any equipment has been added to the vehicle, or if any modifications have been made to the vehicle, that increase its speed or power.

NOTE

The addition of certain accessories, including (but not limited to) mowers, blades, tires, sprayers, or large racks, may change the handling characteristics of the vehicle. Use only approved accessories, and familiarize yourself with their function and effect on the vehicle.

OPERATOR SAFETY

Avoid Burns from Hot Parts

Certain components become hot during operation. Avoid contact with those parts during and shortly after operation to avoid burns.

Pulling a Trailer

Check the maximum axle loads of the vehicle identification plate (statutory plate).

Check the trailer, the maximum loads on the identification plate.

Check the national packages limits the use of a vehicle-trailer on the road. Connect the trailer lights and set the slow moving vehicle triangle behind the trailer.

NOTE

A approved rear hitch must be properly installed on the vehicle for hauling trailers. Riding this vehicle with a trailer substantially increases the risk of toppling, especially on inclined slopes. If a trailer is used behind the vehicle make sure that its hitch is compatible with the one on the vehicle. Make sure the trailer is horizontal with the vehicle. (In some instances a special extension may have to be installed on the vehicle hitch). Use security chains or cables to secure the trailer with the vehicle.

Reduce your speed when pulling a trailer and turn gradually. Avoid hills and rough terrain. Never attempt steep hills. Allow more distance for braking, especially on inclined surfaces and when a passenger is on board. Be careful not to skid or slide.

OPERATOR SAFETY

Safety Training

When you purchased your vehicle, your dealer offered a hands-on safety training course that covers all aspects of vehicle safety. You were also provided with printed materials that explain safe operating procedures. You should review this information on a regular basis. If you purchased a used Vehicle from a party other than a dealer, you can request safety training from any authorized dealer. Familiarize yourself with all laws and regulations concerning the operation of Vehicles in your area. Strongly advises you to strictly follow the recommended maintenance program outlined in your owner's manual. This preventive maintenance program is designed to ensure that all critical components on your vehicle are thoroughly inspected and serviced at specific intervals for safety.

Hazardous Operation Warnings

Serious injury or death can result if you do not follow the following instructions and procedures outlined in further detail within your owner's manual:

WARNING

- Never operate a vehicle without proper instruction.
- Never allow anyone under 16 years of age to operate this vehicle.
- Never permit a guest to operate the vehicle unless the guest has read this manual and all product labels and has completed a certified safety training course.
- Never operate an vehicle without wearing an approved helmet that fits properly. Always wear eye protection (goggles or face shield), gloves, boots, a long-sleeved shirt or jacket, and long pants.
- Never consume alcohol or drugs before or while operating a vehicle.

OPERATOR SAFETY

- Never operate at excessive speeds. Travel at speeds appropriate for the terrain, visibility and operating conditions, and your experience.
- Never attempt wheelies, jumps or other stunts.
- Always inspect your vehicle before each use to make sure it's in safe operating condition.
- Always follow the inspection schedules and maintenance outlined in your owner's manual.
- Always keep both hands on the handlebars and both feet on the foot-rests of the Vehicle during operation.
- Always travel slowly and use extra caution when operating on unfamiliar terrain. Be alert to changing terrain conditions.
- Never operate on excessively rough, slippery, or loose terrain.
- Always follow proper turning procedures as described in this manual. Practice turning at low speeds before attempting to turn at faster speeds. Do not turn at excessive speeds.
- Always have the vehicle inspected by an authorized dealer if it's been involved in an accident.
- Never operate on hills too steep for the vehicle or for your abilities. Practice on smaller hills before attempting larger hills.
- Always follow proper procedures for climbing hills:
 - Check the terrain carefully before ascending a hill.
 - Never climb hills with excessively slippery or loose surfaces.
 - Shift your weight forward.
 - Never open the throttle suddenly or make sudden gear changes.
 - Never go over the top of a hill at high speed.

OPERATOR SAFETY

- Always follow proper procedures for going downhill and for braking on hills:
 - Check the terrain carefully before you start down a hill.
 - Shift your weight backward.
 - Never go down a hill at high speed.
 - Avoid going down a hill at an angle, which would cause the vehicle to lean sharply to one side.
 - Travel straight down the hill when possible.
- Always follow proper procedures for crossing the side of a hill:
 - Avoid hills with excessively slippery or loose surfaces.
 - Shift your weight to the uphill side of the Vehicle.
 - Never attempt to turn the vehicle around on any hill until you've mastered (on level ground) the turning technique outlined in this manual.
 - Avoid crossing the side of a steep hill when possible.
- Always use proper procedures if you stall or roll backwards while climbing a hill:
 - To avoid stalling, maintain a steady speed when climbing a hill.
 - If you stall or roll backwards, follow the special procedure for braking described in this manual.
 - Always dismount on the uphill side, or to either side if the vehicle is pointed straight uphill.
 - Turn the Vehicle around and remount following the procedure described in this manual.
- Always check for obstacles before operating in a new area. Never attempt to operate over large obstacles, such as rocks or fallen trees. Always follow proper procedures when operating over obstacles as described in this manual.

OPERATOR SAFETY

- Always be careful of skidding or sliding. On slippery surfaces like ice, travel slowly and use extra caution to reduce the chance of skidding or sliding out of control.
- Avoid operating the vehicle through deep or fast-flowing water. If it 's unavoidable, travel slowly, balance your weight carefully, avoid sudden movements, and maintain a slow and steady forward motion. Do not make sudden turns or stops, and do not make sudden throttle changes.
- Wet brakes may have reduced stopping ability. Test your brakes after leaving water. If necessary, apply them lightly several times to allow friction to dry out the pads.
- Always check for obstacles or people behind the vehicle before operating in reverse. When it s safe to proceed in reverse, move slowly and avoid turning at sharp angles.
- Brake discs can be overheated after continuous braking. Allow brake disc to cool down before servicing.
- Always use the size and type of tires specified for your vehicle, and always maintain proper tire pressure.
- Never modify an vehicle through improper installation or use of accessories.
- Never exceed the stated load capacity for your vehicle. Cargo must be properly distributed and securely attached. Reduce speed and follow the instructions in this manual for carrying cargo or towing. Allow a greater distance for braking.
- Always remove the ignition key when the vehicle is not in use to prevent unauthorized use or accidental starting.
- Child or pets shall not be carried on the racks.
- Never touch running parts, such as wheels, drive shaft, etc.

FOR MORE INFORMATION ABOUT Vehicle SAFETY, PLEASE CONTACT YOUR DEALER.

OPERATOR SAFETY

⚠WARNING

POTENTIAL HAZARD:

Operating this Vehicle without proper instruction.

WHAT CAN HAPPEN:

The risk of an accident is greatly increased if the operator does not know how to operate the Vehicle properly in different situations and on different types of terrain.

HOW TO AVOID THE HAZARD:

Beginning and inexperienced operators should complete a certified training course offered by a dealer.

Operators should regularly practice the skills learned in the course and the operating techniques described in the owner's manual.

⚠WARNING

POTENTIAL HAZARD:

Failure to follow the age recommendations for this vehicle.

WHAT CAN HAPPEN:

Severe injury and/or death could occur if a child under the minimum age recommendation operates an Vehicle. Even though a child may be within the recommended age group for operating some Vehicles, he/she may not have the skills, abilities or judgment needed to operate an Vehicle safely and could be susceptible to accident or injury.

HOW TO AVOID THE HAZARD:

Operation is prohibited for anyone under 16 years of age.

OPERATOR SAFETY

⚠️ WARNING

POTENTIAL HAZARD:

Carrying a passenger on an Vehicle that is not designed for carrying a passenger.

WHAT CAN HAPPEN:

A passenger riding on the Vehicle could be ejected from the vehicle unexpectedly or make contact with moving components, both of which can result in severe injury or death.

HOW TO AVOID THE HAZARD:

Never allow a passenger on an Vehicle that is not designed for carrying a passenger.

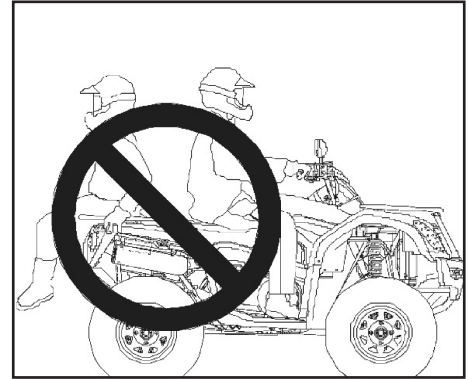

⚠️ WARNING

POTENTIAL HAZARD:

Carrying more passengers than the rated passenger capacity.

WHAT CAN HAPPEN:

Carrying more passengers than the rated capacity greatly reduces the operator's ability to balance and control the Vehicle, which can result in severe injury or death.

HOW TO AVOID THE HAZARD:

Never allow more passengers than the rated passenger capacity.

OPERATOR SAFETY

⚠️ WARNING

POTENTIAL HAZARD:

Operating this Vehicle without wearing an approved helmet, eye protection and protective clothing.

WHAT CAN HAPPEN

Operating an Vehicle without an approved helmet increases the risk of a severe head injury or death in the event of an accident. Operating without eye protection could result in an accident and could increase the chance of a severe eye injury in the event of an accident.

HOW TO AVOID THE HAZARD

Always wear an approved helmet that fits properly.

Always wear eye protection (goggles or face shield), gloves, long-sleeved shirt or jacket, and long pants.

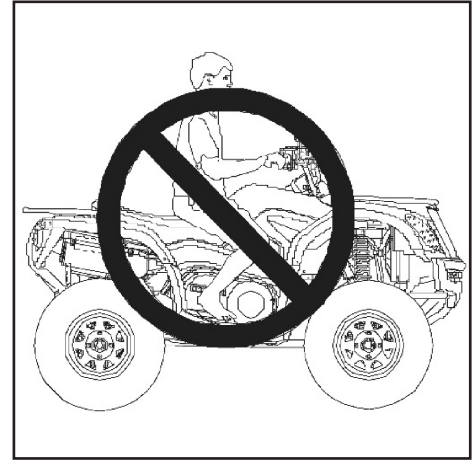

OPERATOR SAFETY

⚠️ WARNING

POTENTIAL HAZARD:

Operating the Vehicle after consuming alcohol or drugs.

WHAT CAN HAPPEN

Consumption of alcohol and/or drugs could seriously affect operator judgment. Reaction time may be slower and operator balance and perception could be affected.

Consumption of alcohol and/or drugs before or while operating an Vehicle could result in an accident causing severe injury or death.

HOW TO AVOID THE HAZARD

Never consume alcohol or drugs before or while operating an Vehicle.



OPERATOR SAFETY

⚠️ WARNING

POTENTIAL HAZARD

Operating the Vehicle at excessive speeds.

WHAT CAN HAPPEN

Excessive speed increase the operator's chance of losing control of the Vehicle, which can result in an accident.

HOW TO AVOID THE HAZARD

Always operate the Vehicle at a speed that is proper for the terrain, visibility and operating conditions, and your experience.

⚠️ WARNING

POTENTIAL HAZARD

Attempting wheelies, jumps and other stunts.

WHAT CAN HAPPEN

Attempting stunts increases the chance of an accident, including an overturn.

HOW TO AVOID THE HAZARD

Never attempt wheelies, jumps, or other stunts. Avoid exhibition driving.

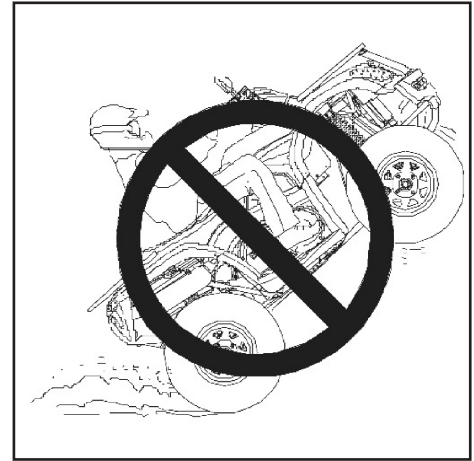

OPERATOR SAFETY

⚠️ WARNING

POTENTIAL HAZARD

Failure to inspect the Vehicle before operating. Failure to properly maintain the Vehicle.

WHAT CAN HAPPEN

Poor maintenance increases the possibility of an accident or equipment damage.

HOW TO AVOID THE HAZARD

Always inspect your Vehicle before each use to make sure it's in safe operating condition.

Always follow the inspection and maintenance procedures and schedules described in the owner's manual.

⚠️ WARNING

POTENTIAL HAZARD

Removing hands from the handlebars or feet from the footrests during operation.

WHAT CAN HAPPEN

Removing even one hand or foot can reduce ability to control the vehicle or could cause loss of balance and ejection from the Vehicle.

If the operator's foot is not firmly planted on the footrest, it could come into contact with the rear wheels and lead to accident or injury.

HOW TO AVOID THE HAZARD

Always keep both hands on the handlebars and both feet on the footrests of the Vehicle during operation.

OPERATOR SAFETY

⚠️ WARNING

POTENTIAL HAZARD

Failure to use extra caution when operating the Vehicle on unfamiliar terrain.

WHAT CAN HAPPEN

Unfamiliar terrain may contain hidden rocks, bumps, or holes that could cause loss of control or overturn.

HOW TO AVOID THE HAZARD

Travel slowly and use extra caution when operating on unfamiliar terrain. Always be alert to changing terrain conditions.

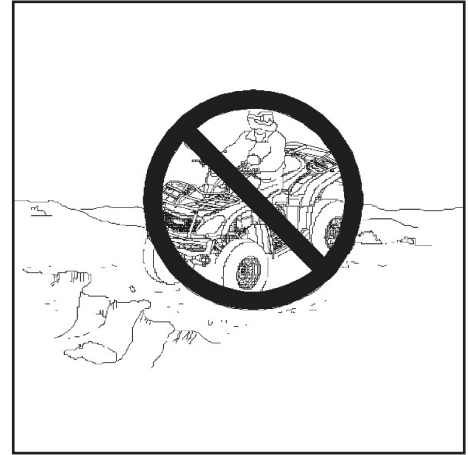

OPERATOR SAFETY

⚠️ WARNING

POTENTIAL HAZARD

Failure to use extra caution when operating on excessively rough, slippery or loose terrain.

WHAT CAN HAPPEN

Operating on excessively rough, slippery or loose terrain could cause loss of traction or loss of control, which could result in an accident or overturn.

HOW TO AVOID THE HAZARD

Do not operate on excessively rough, slippery or loose terrain until you've learned and practiced the skills necessary to control the Vehicle on such terrain. Always use extra caution on rough, slippery or loose terrain.

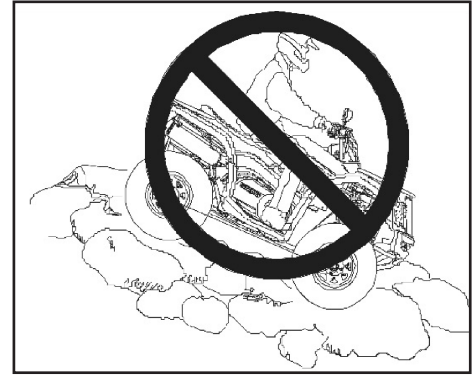

OPERATOR SAFETY

⚠️ WARNING

POTENTIAL HAZARD

Turning improperly.

WHAT CAN HAPPEN

Improper turns could cause loss of control and lead to a collision or overturn.

HOW TO AVOID THE HAZARD

Always follow proper procedures or turning as described in the owner's manual. Practice turning at slow speeds before attempting to turn at faster speeds.

Never turn at excessive speed.

OPERATOR SAFETY

⚠️ WARNING

POTENTIAL HAZARD

Climbing excessively steep hills or climbing hills improperly.

WHAT CAN HAPPEN

Improper hill climbing could cause loss of control or overturn.

HOW TO AVOID THE HAZARD

Always follow proper procedures for climbing hills as described in the owner's manual. Never operate on hills too steep for the Vehicle or for your abilities. Practice on smaller hills before attempting large hills. Always check the terrain carefully before ascending any hill.

Never operate the Vehicle on hills steeper than 20°. Never climb hills with excessively slippery or loose surfaces. Shift your weight forward. Never open the throttle suddenly while traveling uphill.

The Vehicle could flip over backwards. Never go over the top of any hill at high speed. An obstacle, a sharp drop, or another vehicle or person could be on the other side of the hill.

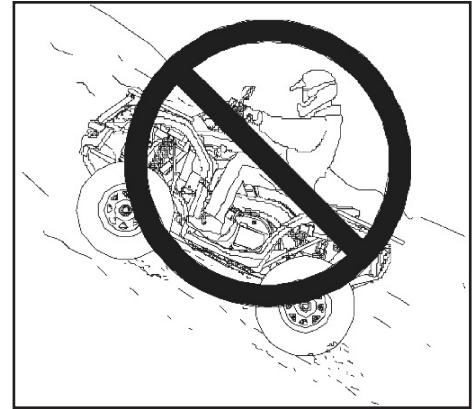

OPERATOR SAFETY

⚠️ WARNING

POTENTIAL HAZARD:

Traveling down excessively steep hills.

WHAT CAN HAPPEN:

Improper downhill travel could cause loss of control or overturn.

HOW TO AVOID THE HAZARD:

Never operate on hills too steep for the Vehicle or for your abilities. Practice on smaller hills before attempting large hills. Always check the terrain carefully before attempting any hill. Never descend hills with excessively slippery or loose surfaces.

NOTE

A special driving and braking technique is required while traveling downhill. Always check the terrain carefully before descending a hill. Shift your weight backward. Never travel down a hill at high speed. Avoid traveling down a hill at an angle, which would cause the vehicle to lean sharply to one side. Travel straight down the hill when possible.

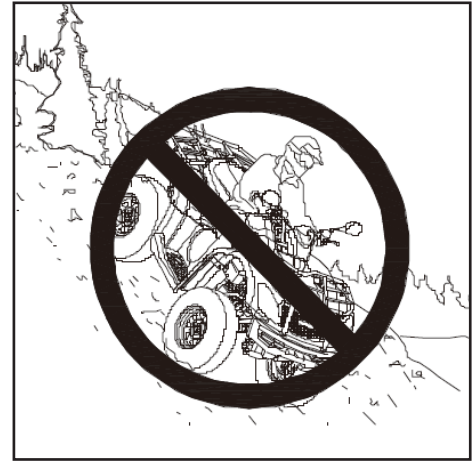

OPERATOR SAFETY

⚠️ WARNING

POTENTIAL HAZARD

Improperly crossing hills and turning on hills.

WHAT CAN HAPPEN

Improperly crossing or turning on hills could cause loss of control or overturn.

HOW TO AVOID THE HAZARD

Never attempt to turn the Vehicle around on any hill until you've mastered the turning technique on level ground as described in the owner' s manual.

Use extra caution when turning on any hill. Avoid crossing the side of a steep hill.

WHEN CROSSING THE SIDE OF A HILL:

Always follow proper procedures as described in the owner' s manual. Avoid hills with excessively slippery or loose surfaces. Shift your weight to use uphill side of the Vehicle.



OPERATOR SAFETY

⚠️ WARNING

POTENTIAL HAZARD

Stalling, rolling backwards or improperly dismounting while climbing a hill.

WHAT CAN HAPPEN

The vehicle could overturn.

HOW TO AVOID THE HAZARD

Maintain steady speed when climbing a hill.

IF ALL FORWARD SPEED IS LOST:

Close the throttle. Keep your weight uphill. Apply the front brake. When fully stopped, apply the foot brake as well, then shift the gear selector to the park position.

IF THE Vehicle BEGINS ROLLING:

Keep weight uphill. Never apply engine power.

Never apply the foot brake while rolling backwards. Apply the front brake. When fully stopped, apply the foot brake and shift the gear selector to the parking position. Dismount on uphill side, or to either side if Vehicle is pointed straight uphill.

Turn the Vehicle around and remount, following the procedure described in the owner's manual.



OPERATOR SAFETY

⚠️ WARNING

POTENTIAL HAZARD

Improperly operating over obstacles.

WHAT CAN HAPPEN

Operating over obstacles could cause loss of control or overturn.

HOW TO AVOID THE HAZARD

Before operating in a new area, check for obstacles.

Avoid operating over large obstacles such as rocks and fallen trees when possible. If unavoidable, use extreme caution and always follow proper procedures as outlined in the owner's manual.

OPERATOR SAFETY

⚠ WARNING

POTENTIAL HAZARD

Skidding or sliding.

WHAT CAN HAPPEN

Skidding or sliding can cause loss of control. If the tires regain traction unexpectedly, the Vehicle could overturn.

HOW TO AVOID THE HAZARD

On slippery surface such as ice, travel slowly and use extra caution to reduce the chance of skidding or sliding out of control.

⚠ WARNING

POTENTIAL HAZARD

Overloading the Vehicle or carrying/towing cargo improperly.

WHAT CAN HAPPEN

Overloading and towing can cause changes in vehicle handling, which could lead to loss of control or an accident.

HOW TO AVOID THE HAZARD

Never exceed the stated load capacity for this Vehicle.

Cargo should be properly distributed and securely attached. Reduce speed when carrying cargo or pulling a trailer. Allow a greater distance for braking. Always follow the instructions in the owner's manual for carrying cargo or pulling a trailer.

OPERATOR SAFETY

⚠️ WARNING

POTENTIAL HAZARD

Operation the Vehicle through deep or fasten-following water.

WHAT CAN HAPPEN

The tires may float, causing loss of traction and loss of control, which lead to an accident or overturn.

HOW TO AVOID THE HAZARD

Avoid operating the Vehicle through deep or fast-flowing water. If it is unavoidable to enter water that exceeds the recommended maximum depth, travel slowly, balance your weight carefully, avoid sudden movements, and maintain a slow and steady forward motion. Do not make sudden turns or stops, and do not make sudden throttle changes. Wet brakes may have reduced stopping ability. Always test the brakes after leaving the water. If necessary, apply brakes several times to dry out the pads.

OPERATOR SAFETY

⚠ WARNING

POTENTIAL HAZARD

Improperly operating in reverse.

WHAT CAN HAPPEN

The Vehicle could collide with an obstacle or person, resulting in severe injury.

HOW TO AVOID THE HAZARD

Before shifting into reverse gear, always check for obstacles or people behind the Vehicle. When it's safe to proceed, back slowly.

⚠ WARNING

POTENTIAL HAZARD

Operating this Vehicle with improper tires, or with improper or uneven tire pressure.

WHAT CAN HAPPEN

Use of improper tires, or operation of the Vehicle with improper or uneven tire pressure, could cause loss of control or accident.

HOW TO AVOID THE HAZARD

Always use the size and type of tires specified in the owner's manual for the Vehicle. Always maintain proper tire pressure.

OPERATOR SAFETY

⚠ WARNING

POTENTIAL HAZARD

Operating the Vehicle with improper modifications.

WHAT CAN HAPPEN

Improper installation of accessories or modification of the Vehicle may cause changes in handling which could lead to an accident.

HOW TO AVOID THE HAZARD

Never modify the Vehicle through improper installation or use of accessories. All parts and accessories added to the vehicle must be genuine parts or equivalent components designed for use on this Vehicle and should be installed and used according to approved instructions. Consult your dealer for more information.

⚠ WARNING

POTENTIAL HAZARD

Operating on frozen bodies of water.

WHAT CAN HAPPEN

Severe injury or death can result if the Vehicle and or the operator fall through the ice.

HOW TO AVOID THE HAZARD

Never operate the Vehicle on a frozen body of water.

OPERATOR SAFETY

⚠️ WARNING

POTENTIAL HAZARD

Improper dismantling and disposal of hazardous materials.

WHAT CAN HAPPEN

It could damage the environment.

HOW TO AVOID THE HAZARD

ALWAYS BE ENVIRONMENTALLY RESPONSIBLE

Follow the guidelines of the governmental agency for the proper disposal of hazardous materials such as engine oil, fuel, engine coolant and machine fluid, grease. Never disposal of hazardous materials irresponsibly by dumping them into a sewer, on the ground, or into groundwater or waterways. Failure to follow these procedures may seriously harm the environment. Comply with legal regulations and guidelines for disposal of: empty containers for fuel, cooling water (coolant), oil, grease; fuel/oil filters; battery; machine itself; machine accessories; and packaging materials.

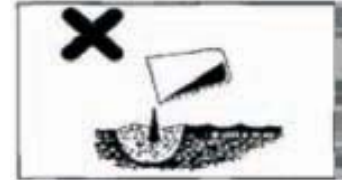

OPERATOR SAFETY

⚠️ WARNING

Leaving the keys in the ignition can lead to unauthorized use of the vehicle, resulting in serious injury or death. Always remove the ignition key when the vehicle is not in use.

⚠️ WARNING

After any overturn or accident, have a qualified service dealer inspect the entire vehicle for possible damage, including (but not limited to) brakes, throttle and steering systems.

⚠️ WARNING

Safe operation of this rider-active vehicle requires good judgment and physical skills.

Persons with cognitive or physical disabilities who operate this vehicle have an increased risk of overturn and loss of control, which could result in severe injury or death.

⚠️ WARNING

Exhaust system components are very hot during and after use of the vehicle. Hot components can cause serious burns and fire. Do not touch hot exhaust system components. Always keep combustible materials away from the exhaust system. Use caution when traveling through tall grass, especially dry grass.

OPERATOR SAFETY

Safe Riding Gear

Always wear clothing suited to the type of riding. Vehicle riding requires special protective clothing for comfort and to reduce the chance of injury.

1 . Helmet

Your helmet is the most important piece of protective gear for safe riding. An approved helmet can prevent a severe head injury.

2 . Eye protection

Do not depend on sunglasses for proper eye protection. A pair of goggles or a helmet face shield offers the best protection for your eyes. They should be kept clean and be shatterproof design.

3 . Gloves

Off- road style gloves with knuckle pads are the best for comfort and protection.

4 . Boots

The best footwear is a pair of strong over- the- calf boots with heels, like motocross boots.

5 . Clothing

Always wear long sleeves and long pants to protect arms and legs. Riding pants with kneepads and a jersey with shoulder pads provide the best protection.

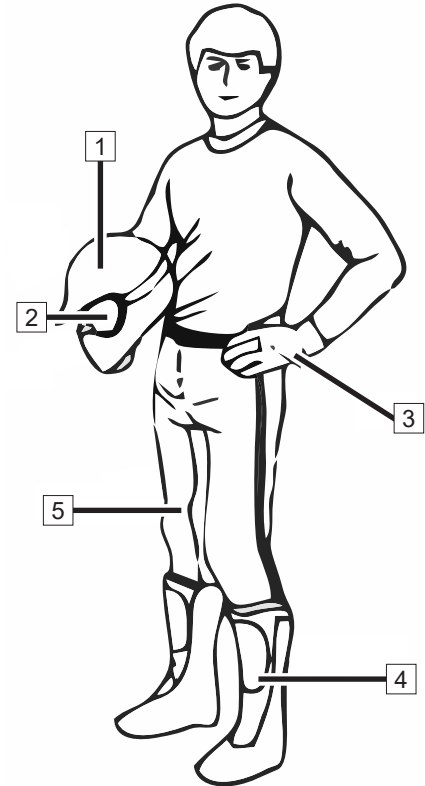

SAFETY DECALS & LOCATIONS

Safety Decals and Locations

Warning decals have been placed on the Vehicle for your protection. Read and follow the instruction on each decal carefully. If a decal becomes illegible or comes off, contact your dealer to purchase a replacement.

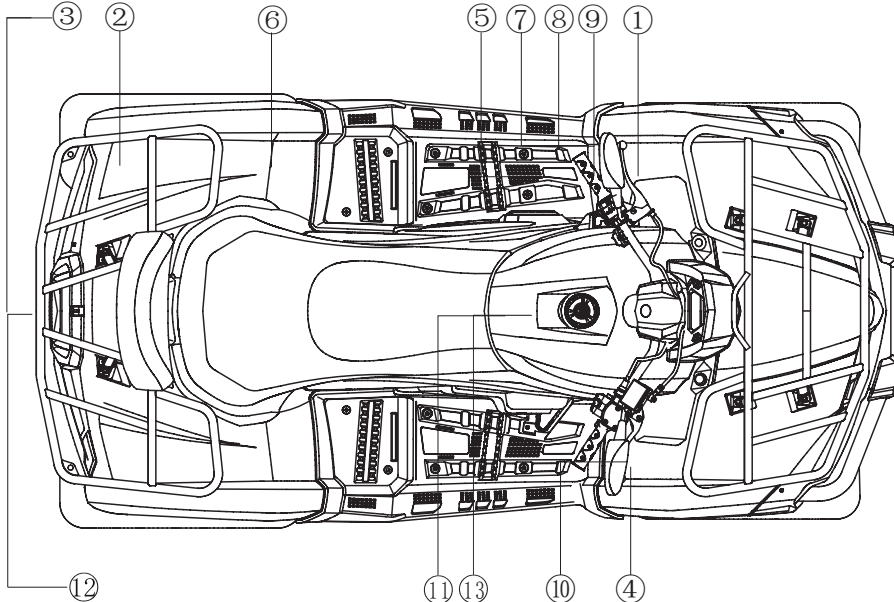

SAFETY DECALS & LOCATIONS

1



2



3

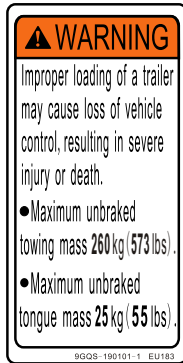

4



5

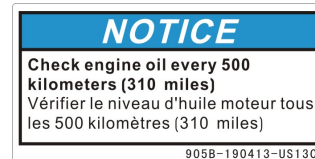

SAFETY DECALS & LOCATIONS

6

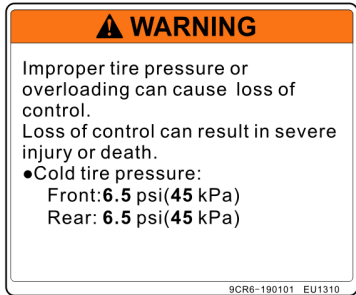

7

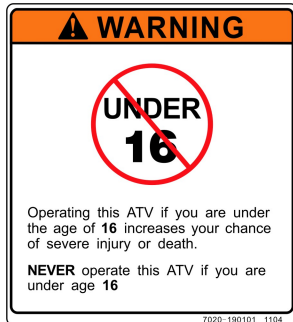

8



SAFETY DECALS & LOCATIONS

9

DRIVE SELECT LEVER

- Read owner's manual carefully before operating.
- ATV **MUST** be stopped before shifting select lever.
- Shifting into or from reverse or park is impossible without applying rear brake

11

⚠ WARNING



Never carry more than one passenger!
Never drive with a passenger unless passenger seat is securely in place!
Passenger must hold firmly the handgrips during riding!

10

⚠ WARNING

Turning the ATV in 4WD-LOCK ("DIFF. LOCK") takes more effort

Operate at a slow speed and allow extra time and distance for maneuvers to avoid loss of control

13

E5



Bleifreies Benzin 

Unleaded fuel only

Carburant sans plomb

Gasolina sin plomo

Bezolovnatý benzin

Endast blyfri bensin

RON/ROZ min. **95**

E10

9GQA-190201-1 EU187

12

⚠ WARNING

NEVER attach here or on the luggage rack to pull a load This can cause the vehicle to tip over. ALWAYS use the trailer hitch or the recovery hook to pull a load.

⚠



9CR0-190102 EU153

SAFETY DECALS & LOCATIONS

Features and Controls Left Hand Controls

1 Override Button

Top speed is normally limited when operating in 4WD-LOCK and REVERSE. If conditions require more engine power when proceeding, press this button to override the speed limiting function. Releasing the button restores the speed limiting function. While this button is depressed, the override indicator light will be on.

⚠ WARNING

Pressing the override button while the throttle is open in speed limiting mode may cause sudden acceleration, resulting in a loss of control, severe injury, or death. Always release the throttle before pressing the override button.

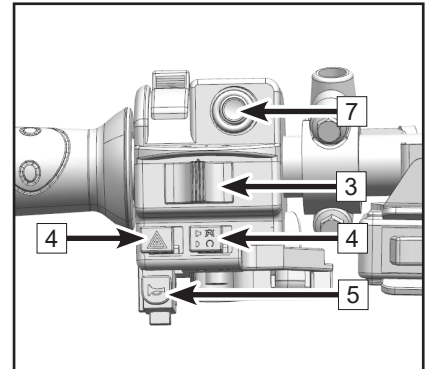
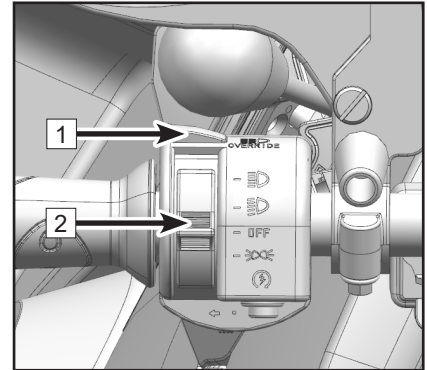

SAFETY DECALS & LOCATIONS

2 Headlight Switch

The headlight switch consists of 4 positions: “”, “”, “OFF”.

: When the switch is at this position, Hi beam, tail light, instrument light and license plate light are on.

: When the switch is at this position, Lo beam, tail light, instrument light and license plate light are on.

OFF: When the switch is at this position, all lights are off.

: When the switch is at this position, the tail light, position light, license plate light and instrument light are on. Headlights are off.

6 Turn Switch

Move the switch to this position  , left turn signal indicator will be on.

Move the switch to this position  , right turn signal indicator will be on.

5 Hazard Switch

Depress the button  , front turn lights, rear turn lights and turn signal indicators on dashboard are on.

CAUTION

Do not use the headlights with the engine turned off for more than 15 minutes. The battery may discharge to the point that the starter motor will not operate properly. If this should happen, remove the battery and recharge it.

SAFETY DECALS & LOCATIONS

5 Horn Button



Press the button “”. The horn will sound.

6 Engine Stop Switch

: When the switch is moved to this position, the engine shuts off.

: When the switch is moved to this position, the engine can be started.

7 Starter Switch

When the main key switch is turned to “ON”, and the engine stop switch is at this position , push button  to start the engine.

8 Left parking brake lever - (If equipped)

The left parking brake lever  is located on the left handlebar. Pull the lever toward the handlebar to apply parking brakes.

The left parking brake on the left handlebar can not be used for braking the vehicle during running.

Adjust switch  if you need parking brake when vehicle comes to a full halt.

WARNING

Auxiliary parking brake can not be used in sloping road.

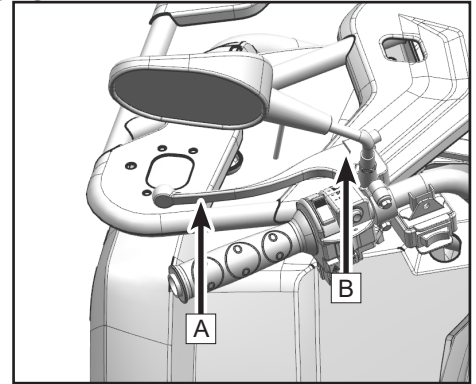

SAFETY DECALS & LOCATIONS

Right Hand Controls

1 Front Brake

The front brake lever **1** is located on the right handlebar and controls only the front brakes. Pull it toward the handlebar to apply the front brake. When squeezed, the lever should feel firm. Any sponginess would indicate a possible fluid leak or low master cylinder fluid level, which must be corrected before riding. Contact your dealer for proper diagnosis and repairs.

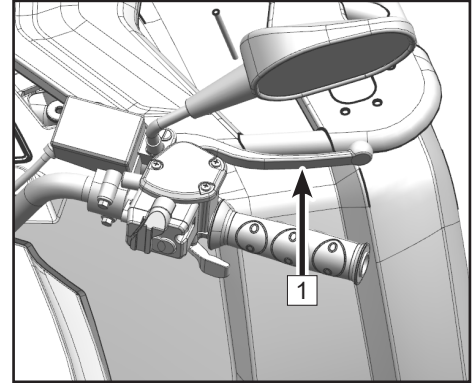

2 Front Brake Fluid Reservoir and Level Indicator

Check the fluid level in the front brake fluid reservoir before each use of the Vehicle. The front brake fluid reservoir is located on the right handlebar. The fluid level can be viewed through the indicator window on the side of the master cylinder. If the fluid level is lower than the “lower” mark, refill with brake fluid as necessary.

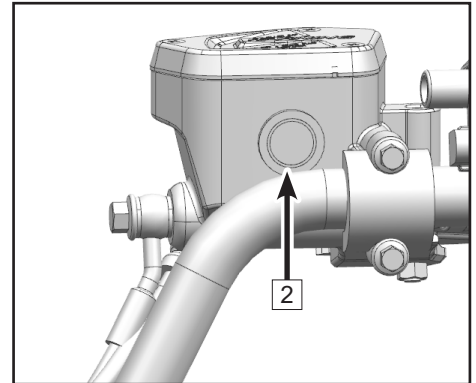

⚠ WARNING

An over-full master cylinder may cause brake drag or brake lock-up, which could result in serious injury or death. Maintain brake fluid at the recommended level. Do not overfill.

SAFETY DECALS & LOCATIONS

3 2WD / 4WD System Switch

This vehicle is equipped with an on-command four-wheel drive switch “2WD”/“4WD” [A] and a front diff-lock switch “LOCK”/“4WD” [B]. Select the appropriate drive according to terrain and the conditions.

- Two-wheel drive (2WD) :Power is supplied to the rear wheels only.
- Four-wheel drive (4WD) :Power is supplied to the rear and front wheels.
- Four-wheel drive with the front diff- locked (4WD-LOCK): Power is supplied to the rear and front wheels when the front diff is locked. Unlike the 4WD mode, all wheels turn at the same speed. Speed is limited to 22 mph (35 km/h).

On-command four-wheel drive switch

“ 2WD ” / “ 4WD ” [A]: To change from 2WD to 4WD, stop the vehicle. Then set the switch to “ 4WD ”, when the vehicle is in 4WD, the 4WD indicator “  ” will display in the dashboard.

To change from 4WD to 2WD, stop the vehicle, be sure the lever [B] is moved to the front diff-lock switch, and then set the switch [A] to “ 2WD ”. When the vehicle is in 2WD, the indicator “  ” will display in the dashboard.

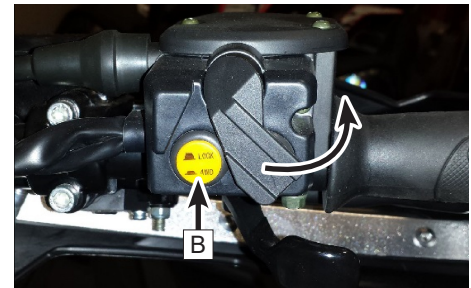
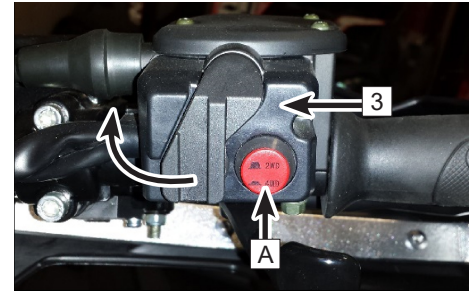

SAFETY DECALS & LOCATIONS

Front Diff-lock Switch “LOCK”/”4WD”

To lock the front diff in 4WD, make sure the on-command four-wheel-drive switch is set to 4WD, stop the vehicle, move the lever **A** to 2WD/4WD switch, then set the switch **A** to LOCK, when the front diff is locked, the The 4WDLOCK indicator “” will display .

NOTE

- When the switch is set to “LOCK”, the front diff-lock indicator light will flash until the front diff is locked.
- When the indicator light is flashing, turning the handlebar left and right will help the front gear lock to engage.
- Riding before the front diff-lock is properly engaged (e.g., when the indicator light is flashing) will cause the engine speed to be limited until engagement is complete.
- When the vehicle is in 4WD-LOCK, the maximum traveling speed is limited to 30 km/h (19 mph). However, if conditions require full engine power to be available, depress the override switch to disable the 4WD-LOCK speed limiter.



SAFETY DECALS & LOCATIONS

4 Throttle Lever

Before starting the engine, check the throttle to be sure it is operating smoothly. Make sure it returns to the idle position as soon as the lever is released.

Once the engine is running, movement of the throttle lever using your thumb will increase the engine speed. Regulate the speed of the vehicle by varying the throttle position. Because the throttle is spring loaded, the vehicle will decelerate and the engine will return to idle speed any time your thumb is removed from the throttle lever.

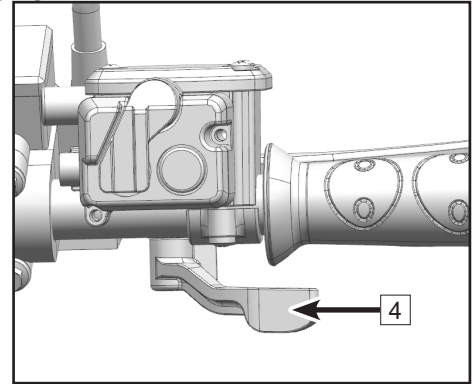

CAUTION

Check the operation of the throttle lever before you start the engine. If it does not work smoothly, check for the cause. Correct the problem before riding the vehicle. Consult your dealer if you can't find or solve the problem by yourself.

SAFETY DECALS & LOCATIONS

5 Mechanical Speed Limiter

A mechanical speed limiter keeps the throttle from fully opening, even when the throttle lever is pushed to the maximum travel.

Turning the screw **A** limits the throttle lever travel, which reduces the maximum engine power available and decreases the maximum speed of the vehicle.

NOTE

Your Vehicle is set for maximum throttle opening from the factory.

⚠ CAUTION

Do not turn the adjusting screw out more than 12 mm (0.47 in.). Always make sure the throttle lever free play remains adjusted to 3mm~5mm (0.12 in~0.20 in). Tighten the locking nut when the adjustment is completed.

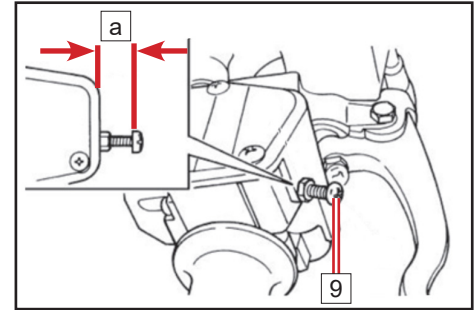

SAFETY DECALS & LOCATIONS

Foot Controls

1 Foot Brake

The foot brake pedal is located on the right side floor board of the vehicle. Push down on the pedal to apply both the front and rear brakes. When pressed, the pedal should feel firm. A soft brake pedal would indicate a possible fluid leak or low master cylinder fluid level, which must be corrected before riding. Contact your dealer for proper diagnosis and repairs.

2 Foot Brake Fluid Reservoir and Level Indicator

Check the fluid level of foot brake fluid reservoir before each use of the vehicle. The foot brake fluid reservoir is near the right foot rest under the front access panel. The fluid level can be viewed on the side of the fluid reservoir. If the fluid level is lower than the “lower” mark, refill with brake fluid DOT4 as necessary.

⚠️ WARNING

An over-full master cylinder may cause brake drag or brake lock-up, which could result in serious injury or death. Maintain brake fluid at the recommended level. Do not overfill. Never store or use a partial bottle of brake fluid. Brake fluid is hygroscopic, meaning it rapidly absorbs moisture from the air. The moisture causes the drop of boiling temperature of the brake fluid, which can lead to early brake fade and the possibility of accident or severe injury. After opening a bottle of brake fluid, always discard any unused portion.

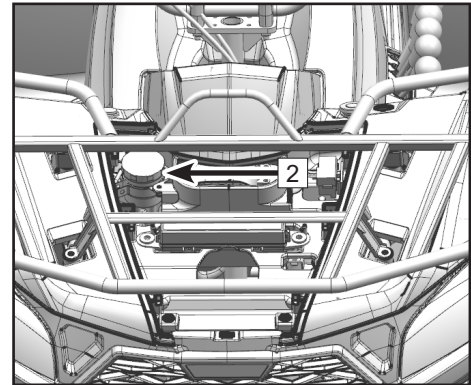
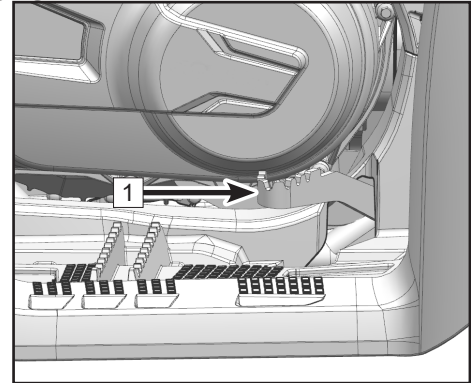



SAFETY DECALS & LOCATIONS

Vehicle Features

1 Main Switch

Functions of the respective switch positions are as follows:

 :The engine can be started only at this position and the headlights and taillight come on when the light switch is on. The key can not be removed in this position.

 :All electrical circuits are switched off. The key can be removed in this position.

NOTE

Remove and store the spare key in a safe place. Your key can be duplicated only by mating a key blank with one of your existing keys. If both keys are lost, the complete switch assembly must be replaced.

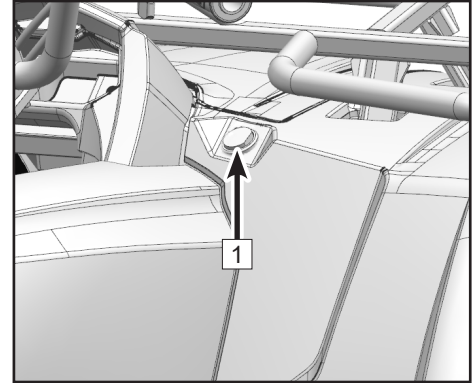

SAFETY DECALS & LOCATIONS

2 Fuel Tank

The fuel tank fill cap is located at the top of the vehicle behind the handlebars. Cap removal is left-handed rotation. Cap installation is right-handed rotation.

Fuel Minimum Octane Rating

The recommended fuel for your Vehicle is minimum 95 Octane unleaded. Non-oxygenated (ethanol-free) fuel is recommended for best performance in all conditions.

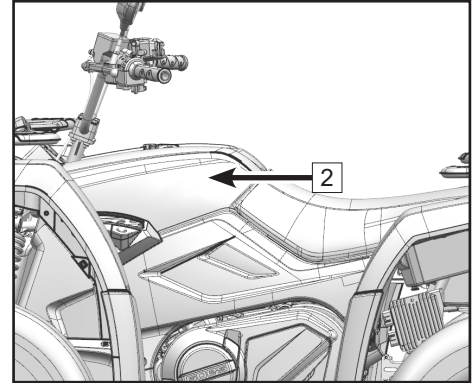

SAFETY DECALS & LOCATIONS

Fuel safety

WARNING

Gasoline is highly flammable and explosive under certain conditions.

- Always exercise extreme caution whenever handling gasoline.
- Always refuel with the engine stopped, and outdoors or in a well ventilated area.
- Never carry a plastic container with gasoline in the racks while riding. Static electricity between the rack and container could cause a spark.
- Do not smoke or allow open flames or sparks in or near the area where refueling is performed or where gasoline is stored.
- Do not overfill the tank. Do not fill the tank neck.
- If gasoline spills on your skin or clothing, immediately wash it off with soap and water and change clothing.
- Never start the engine or let it run in an enclosed area. Engine exhaust fumes are poisonous and can cause loss of consciousness or death in a short time.

WARNING

The engine exhaust from this product contains chemicals known to cause cancer, birth defects or other reproductive harm. Operate this vehicle only outdoors or in well-ventilated areas.

SAFETY DECALS & LOCATIONS

3 Transmission Gear Selector

The transmission gear selector is located on the left side of the vehicle:

Gear Pattern

L – Low Gear

H – High Gear

R – Reverse Gear

P – Park

Selector Direction

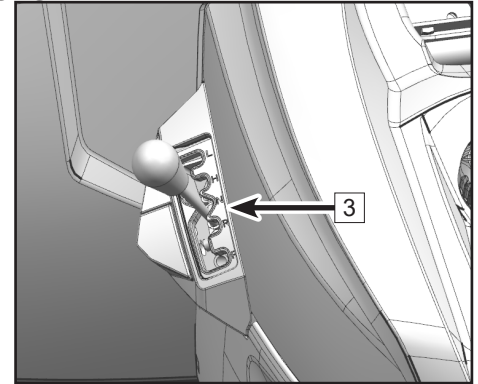

⚠ CAUTION

Always stop the Vehicle and press the foot brake pedal before shifting the transmission.

When operating under L gear, the maximum speed is limited at 30 km/h.

SAFETY DECALS & LOCATIONS

4 Parking

When parking, stop the engine and shift the gear selector Lever 4 into the park position.

CAUTION: When shifting the transmission in PARK, always push the brake pedal.

Shake the vehicle forward and backward to check if the parking brake is engaged.

⚠️ WARNING

Never depend on the parking brake alone if the vehicle is parked on a hill. Always block the wheels on the downhill side of the vehicle to prevent rolling. It's recommended to park the vehicle on a level ground.

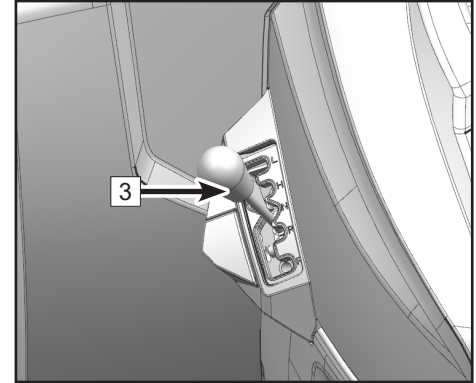

SAFETY DECALS & LOCATIONS

12 Volt Accessory and USB Power

Auxiliary 12Vdc and USB power outlets are provided on the left side front fender area for operating accessories such as hand held spot lights and charging electronic devices. Please consult with your dealer on the use of powered accessories with your vehicle.

Towing

This vehicle is equipped with a hitch receiver for towing trailers. Please consult with your dealer about towing, the use of trailers, and available accessories for connecting a trailer to the vehicle.

Front panel access

Your vehicle is equipped with an access panel under the front rack.

To remove the panel:

1. Lift the nose of the panel until you release the pin from the grommet.
2. Lift up lightly on the nose of the panel and press down in the center, then apply force toward the rear of the machine to release the six (6) L-shaped fasteners and remove.

To reinstall the panel:

1. Start at the rear of the cover and align the six (6) L-shaped fasteners.
2. Press down in the center of the cover and pull it toward you.
3. Guide and push the nose pin into the grommet to secure the panel.

Winch

This vehicle is equipped with a 2500-lb winch. The winch control is located on the left handle bar. To preserve battery power, only operate the winch when the engine is running. Please consult with your dealer on the use of the winch before using your vehicle.

SAFETY DECALS & LOCATIONS

GENERAL SAFETY PRECAUTIONS REGARDING THE USE OF WINCH

WARNING

Moving Part Hazards

To prevent serious injury and property damage:

- Do not operate or install winch without reading and understanding these instructions and the Basic Guide to Winching Techniques.
- Keep hands clear of wire rope, hook and fairlead opening during operation and when spooling.
- Use supplied hook strap for spooling wire rope.
- Stand clear of wire rope and load during operation.
- Keep others away.
- Inspect winch installation and wire rope condition before operating winch
- Do not use as a hoist.
- Do not use to move persons.
- Do not exceed winch's rated capacity.
- Never touch wire rope or hook while in tension.
- Be certain the anchor you select will withstand load.
- Never wrap wire rope back onto itself. Use a choker chain or tree trunk protector on the anchor.

- Prior to initiating winching operation be sure any element which can interfere with safe winching is removed.
- Do not disengage clutch if winch is under load or wire rope is in tension.
- Take your time. Sloppy rigging causes accidents.
- The wire rope must always spool onto the drum as indicated by the drum rotation label on the winch.

CAUTION

To avoid injury and property damage:

- Do not use winch to secure a load during transport.
- Do not submerge in water.
- Do not use to tow other vehicles.
- Wear heavy leather gloves when handling the wire rope.
- Never winch with less than 5 wraps of wire rope around the drum.
- Caution should be used if the vehicle is tied down during a winching operation. This may lead to damage to the frame.
- Before winching, inspect remote control lead for damage.

SAFETY DECALS & LOCATIONS

Winch

This vehicle is equipped with a 3000-lb winch. The winch control is located on the left handle bar. To preserve battery power, only operate the winch when the engine is running. Please consult with your dealer on the use of the winch before using your vehicle.

GENERAL SAFETY PRECAUTIONS REGARDING THE USE OF WINCH

Moving Part Hazards

To prevent serious injury and property damage:

- Do not operate or install winch without reading and understanding these instructions and the Basic Guide to Winching Techniques.
- Keep hands clear of wire rope, hook and fairlead opening during operation and when spooling.
- Use supplied hook strap for spooling wire rope.
- Stand clear of wire rope and load during operation.
- Keep others away.
- Inspect winch installation and wire rope condition before operating winch
- Do not use as a hoist.
- Do not use to move persons.
- Do not exceed winch's rated capacity.
- Never touch wire rope or hook while in tension.
- Be certain the anchor you select will withstand load.
- Never wrap wire rope back onto itself. Use a choker chain or tree trunk protector on the anchor.

SAFETY DECALS & LOCATIONS

- Prior to initiating winching operation be sure any element which can interfere with safe winching is removed.
- Do not disengage clutch if winch is under load or wire rope is in tension.
- Take your time. Sloppy rigging causes accidents.
- The wire rope must always spool onto the drum as indicated by the drum rotation label on the winch.

To avoid injury and property damage:

- Do not use winch to secure a load during transport.
- Do not submerge in water.
- Do not use to tow other vehicles.
- Wear heavy leather gloves when handling the wire rope.
- Never winch with less than 5 wraps of wire rope around the drum.
- Caution should be used if the vehicle is tied down during a winching operation. This may lead to damage to the frame.

SAFETY DECALS & LOCATIONS

Winch Operation

(Select Markets) Your vehicle may be equipped with a winch that can pull certain capacities and types of loads. It is useful for vehicle self-recovery when stuck, assisting another vehicle in recovery, moving fallen trees, removing brush, etc.

Consider practicing the operation and use of your winch before you actually need to use it.

The safety warnings, operating precautions and instructions in this section apply if your vehicle came equipped with a winch, or if you choose to install an accessory winch on your vehicle:

Winch Safety Warnings

These safety warnings apply if your vehicle is equipped with a winch, or if you choose to install an accessory winch on your vehicle:

- Read and understand all sections of this manual.
- Improper winch use or failure to correctly follow the winch guidelines, instructions, and warnings in this manual can result in SEVERE INJURY or DEATH.
- Improper or lack of winch maintenance and service could lead to SEVERE INJURY or DEATH.
- Always keep body, hair, clothing, and jewelry clear of the winch cable, fairlead, and hook during winch operation.
- Always keep the area around the vehicle, winch, winch cable and load clear of people, pets, and distractions during winch operation.
- Always wear eye protection and heavy gloves during winch operation.
- Never use alcohol or drugs before or while operating the winch.
- Never allow children under 16 years of age to operate the winch.

SAFETY DECALS & LOCATIONS

- Never attempt to “jerk” a load attached to the winch by moving the vehicle.
- Never winch up or down, or to the sides at sharp angles. This can destabilize the winching vehicle and possibly cause it to move without warning.
- Never attempt to winch loads that weigh more than the winch capacity rating.
- Never touch, push, pull, or straddle the cable while winching a load.
- Never let the winch cable run through your hands, even if wearing heavy gloves.
- Never release the drum on the winch when the winch cable is under load.
- Never use the winch for lifting or transporting people.
- Never use the winch to hoist or suspend a vertical load.
- Never retract the hook fully into the winch. This can cause damage to system components.
- Never operate the winch or the vehicle if they are in need of repair or service.
- Always turn the ignition switch OFF and unplug the remote control (if equipped) to prevent inadvertent activation or unauthorized use when the vehicle or winch are not being used.

Winch Operating Precautions

These operating precautions should always be followed if your vehicle is equipped with a winch, or if you choose to install an accessory winch on your vehicle:

- Always inspect your winch and winch cable before each use.
- Always use the provided hook strap when pulling cable out or guiding cable in. Never grab the hook.
- Always align the load directly in front of the vehicle and winch as much as possible. Avoid winching with the cable at a sharp angle to the winching vehicle’s centerline whenever possible.

SAFETY DECALS & LOCATIONS

- If winching at an angle is unavoidable, follow these precautions while operating:
- A. Look at the winch drum occasionally. Never let the winch cable “stack” or accumulate at one end of the drum. Too much cable at one end of the drum can damage the winch and cable.
- B. If cable stacking occurs, stop winching. Follow the ‘Winch Cable Spooling Guidelines’ section in this manual to redistribute the cable evenly before continuing.
- Always apply the vehicle’s park brake and/or park mechanism to hold the vehicle in place during winching. Use wheel chocks when necessary.
- Always maintain at least five full turns of cable wrapped around the winch drum at all times. The friction provided by the wrapped cable allows the drum to pull on the winch cable and move the load.
- Never grease or oil the winch cable. This will cause the winch cable to collect debris that will shorten the life of the cable.
- The winch motor and relay connector may become hot during continuous use. When winching for more than 45 seconds, or if the winch stalls during operation, stop and allow the winch components to cool for a minimum of 10 minutes before using it again.
- Never operate the winch without running the engine. The engine’s charging system helps keep the battery maintained. Battery reserve capacity can be quickly exhausted by heavy winch use, rendering the starting system inoperable.
- Always operate with concern for the environment. Do not purposely damage trees, etc.

Basic Winch Operation

Follow these operating instructions if your vehicle is equipped with a winch, or if you choose to install an accessory winch on your vehicle. Read *Winch Safety Warnings and Winch Operating Precautions* on the preceding pages before using your winch.

SAFETY DECALS & LOCATIONS

BEFORE YOU BEGIN - Realize that each winching situation is unique:

- Take your time to think through the winch operation you are about to perform.
 - Proceed slowly and deliberately.
 - Never hurry or rush during winching.
 - Always pay attention to your surroundings.
 - Be prepared to change your winching strategy if it is not working.
 - Remember that although your winch is very powerful, there are simply some situations that you and the winch will not be able to deal with. Do not be afraid to ask others for help when necessary.
1. Always inspect the vehicle, winch, cable and controls for signs of damage or parts in need of repair before each use. Pay particular attention to the first 3 feet (1 meter) of winch cable if the winch is used (or has been used) for lifting a plow. Promptly replace any worn or damaged cable.
 2. Apply the vehicle's park brake and/or park mechanism to hold the vehicle in place during winching. Use wheel chocks when necessary.
 3. Release the winch drum and pull out the required length of cable. Always use the hook strap to handle the hook. Never remove the hook strap from the hook.

CAUTION: Always maintain a minimum of five (5) full turns of cable around the winch drum at all times. The friction provided by wrapping cable allows the drum to pull on the cable and move the load.

4. Attach the hook onto the load, or use a tow strap or chain to secure the load to the winch hook. Never hook the winch cable back onto itself. This can damage the winch cable and result in cable failure.

SAFETY DECALS & LOCATIONS

WARNING: Never use a 'recovery strap' for winching. Recovery straps are designed to stretch and could release excessive energy that can result in SEVERE INJURY or DEATH if the strap or winch cable breaks. Use only undamaged tow straps or chains that do not stretch.

5. Re-engage the winch drum.
6. Slowly winch in slack of the winch cable until it is gone, then stop and follow the instructions for 'winch damping' to ensure safe operation:
 - A. Place a damper on the mid-point of winch cable length to absorb energy that could be released by a winch cable failure. A damper can be a heavy jacket, tarp, or other soft, dense object. A damper can absorb much of the energy released if the cable breaks during winching. Even a tree limb can help as a damper if no other items are available to you.
 - B. Lay the damper on top of the mid-point of the winch cable length.
 - C. On a long pull, it may be necessary to stop winching so the damper can be repositioned to a new mid-point. Always release the tension on the winch cable before repositioning the damper.
 - D. Avoid being directly in line with the winch cable whenever possible. Also, never permit others to stand near or in line with the winch cable during winch operation.
7. Stop winching as soon as the job is completed or the load can be moved without the help of the winch.
8. Detach the winch hook, then rewind the cable evenly back onto the drum following the instructions in this manual.

SAFETY DECALS & LOCATIONS

Vehicle Recovery Methods

Vehicle Self-Recovery:

- A. Release the winch drum and pull out the required length of cable.
- B. Whenever possible, pick an anchor point that aligns the winch cable to the vehicle's centerline as close as possible. This will help the spooling of the winch cable and reduce the load on the fairlead.
- C. Attach the winch hook to an anchor point. NOTE: If freeing a stuck vehicle by attaching to a tree, use an item such as a tow strap to avoid damaging the tree during winch operation. Sharp cables and chains can damage and even kill trees. Always respect the environment.
- D. Re-engage the winch drum.
- E. Slowly winch in any slack in the winch cable, then damper it.
- F. Shift to the lowest gear available that will propel the vehicle in the direction of winching.
- G. Carefully apply winch power and throttle together to free the vehicle.

CAUTION: Using the vehicle throttle and winching at the same time has risk and is optional. Place the vehicle in neutral and use only the winch if unsure of your operating abilities.

- H. Stop winching as soon as the stuck vehicle is able to propel itself without the help of the winch.
- I. Detach the winch hook, then rewind the cable evenly back onto the drum following the instructions in this manual.

CAUTION: The ONLY time a winch-equipped vehicle should be moving and using the winch is for self-recovery. The winch-equipped vehicle should NEVER use motion to “shock-load” the winch cable in an attempt to recover a second stuck vehicle. See ‘Winch Shock Loading’ section in this manual for more information.

SAFETY DECALS & LOCATIONS

Recovery of Another Vehicle:

- A. Release the winch drum and pull out the necessary length of cable.
- B. Attach the winch hook to the vehicle. Whenever possible, pick an anchor point on the stuck vehicle that aligns the winch cable to the winching vehicle's centerline as close as possible. This will help the spooling of the winch cable and reduce the load on the fairlead.

CAUTION: Never attach the winch hook to a suspension component, brush guard, bumper or cargo rack. Vehicle damage may result. Always attach the hook to the strongest available portion of the vehicle frame or hitch.

- C. Re-engage the winch drum.
- D. Slowly winch in any slack in the winch cable, then damper it.
- E. Shift to the lowest gear available on the stuck vehicle that will propel it in the direction of winching.
- F. Carefully apply winch power and the stuck vehicle's throttle together to free it.
- G. Stop winching as soon as the stuck vehicle is able to propel itself without the help of the winch.
- H. Detach the winch hook, then rewind the cable evenly back onto the drum following the instructions in this manual.

Winch Cable Care

Always inspect your winch cable before each use for worn or kinked winch cable. Never use a cable that is damaged. Follow these guidelines for inspection and use:

- A winch cable made of wire rope that is kinked, deformed, or bent is permanently and severely damaged. Promptly discontinue use of a winch cable in this condition.

SAFETY DECALS & LOCATIONS

- A kinked winch cable made of wire rope that has been “straightened out”, even though it may look usable, has been permanently and severely damaged. It can no longer achieve its load capacity rating. Promptly discontinue use of a winch cable in this condition.
- A winch cable made of synthetic rope should be inspected for signs of fraying. Replace the cable if fraying is observed. Promptly discontinue use of a winch cable in this condition.
- Replace synthetic winch cable if fused or melted fibers are discovered. The synthetic rope will be stiff and appear smooth or glazed in the damaged section. Promptly discontinue use of a winch cable in this condition.
- Never replace a synthetic winch cable with consumer-grade polymer rope. Only use cable that is specifically designed for winch use.
- Never grease or oil a wire rope winch cable. This will cause the cable to collect debris that will shorten the life of the cable.
- Never operate the winch with a damaged hook or latch. Always replace damaged parts before using the winch.

WARNING: Replace the winch cable and components at the first sign of damage to prevent SEVERE INJURY or DEATH in the event of failure.

Winch Cable Spooling Guidelines

After winching is complete, especially if winching at an angle, it may be necessary to respool the winch cable evenly across the drum. This reduces the chances of the winch cable “wedging” itself between lower layers of cable. You will need an assistant to perform this task:

- A. Release the winch drum.

SAFETY DECALS & LOCATIONS

- B. Pull out the winch cable that is wrapped unevenly onto the drum.
- C. Re-engage the winch drum.
- D. Have an assistant pull the winch cable hook strap tightly to apply about 100 lbs. (45 kg) of tension.
- E. Slowly winch the cable in while the assistant moves the end of the cable back and forth horizontally to evenly distribute it onto the drum.

Winch ‘Shock Loading’

Your winch (if equipped) is designed and tested to withstand the loads produced when operated from a stationary vehicle. Always remember that the winch, cable and components are NOT designed for shock loading. Follow these guidelines:

- Never attempt to “jerk” a load with the winch. For example, never take up cable slack by moving the winching vehicle in an attempt to move an object. This is a dangerous practice that generates high loads which may exceed the strength of the components. Even a slow moving vehicle can create a large shock load which can cause damage.
- Never quickly turn the winch ON and OFF repeatedly (“jogging”). This is a form of shock loading. This puts extra load on the winch components, the cable, and generates excessive heat in the motor and relay assembly.
- Never tow a vehicle or other object with your winch. Towing with a winch produces shock loading even when towing at slow speeds. Towing from the winch also positions the towing force high on the vehicle, which can cause vehicle instability and the possibility of an accident.

SAFETY DECALS & LOCATIONS

- Never use recovery straps with your winch. This is a form of shock loading. Recovery straps are designed to stretch and can store energy. Stored energy in the recovery strap is released if a failure occurs, making the event even more hazardous. Similarly, never use elastic “bungie” cords for winching.
- Never use the winch to tie down the vehicle to a trailer or other transporting unit. This is a form of shock loading that can cause damage to the winch components, the cable, or the transporting unit.

Tool Kit

Tool Kit **A** is located under the seat.

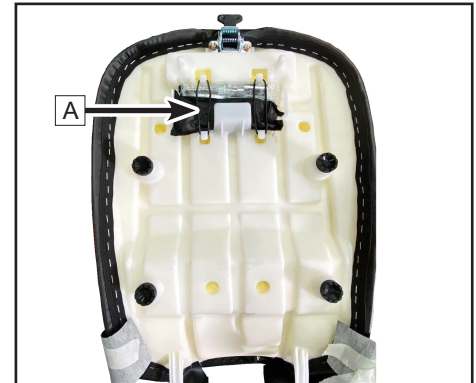

SAFETY DECALS & LOCATIONS

Alarm

This vehicle is configured with an alarm that performs the following functions:

- When oil pressure signal is in GND, and oil pressure $<0.06\text{mpa}$, alarm sounds one short/time. When the oil pressure rises to the normal range, the alarm disappears.
- If water temperature is $\geq 115^{\circ}\text{C}$, alarm sounds two short/time. When the water temperature returns to the normal range, the alarm disappears.
- When engine speed is $\geq 7000\text{rpm}$, alarm sounds three short/time. When the engine speed returns to the normal range, the alarm disappears.

SAFETY DECALS & LOCATIONS

CVT System

This vehicle has a Continuously Variable Transmission (CVT) system that utilizes a belt and clutch pulleys to automatically vary transmission ratios, allowing infinite variability between the highest and lowest vehicle speeds with no discrete steps or shifts.

The CVT consists of a primary clutch [1], which is an advanced form of centrifugal clutch that is mounted to the engine crankshaft [A].

The secondary clutch [2] is mounted to the input shaft of the transmission [B] and serves two functions: As a “slave” pulley to the primary clutch, and to provide a torque sensing element. The drive belt [3] is a heavy duty V-belt that connects the engine and transmission pulleys.

A CVT housing and cover encloses the clutches and belt assembly. It has inlet and outlet cooling ducts that route air to cool the components, and they should be inspected. The CVT components do not contain any user maintenance items. Contact your dealer for service.

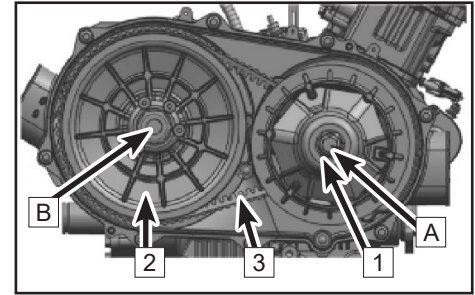

SAFETY DECALS & LOCATIONS

Engine Braking System (EBS)

This vehicle is equipped with an engine braking system. The CVT primary clutch mounted to the engine crankshaft contains a one-way bearing that creates engine braking, which occurs when the throttle is completely closed, the engine is below the primary clutch engagement RPM, and the vehicle is at speed. It uses the engine's compression/resistive force to slow the over-driving transmission speed via the CVT drive belt, thereby slowing the entire vehicle gradually.

Engine braking is always active, and offers the most benefit when:

Used in conjunction with 4WD and 4WD Diff-Lock Modes.

Descending steep or slippery hills.

Descending rocky downhill terrain.

Slowing while towing heavy loads.

Assisting normal brake system application.

EBS is not a substitute for the vehicle brake system, although increased brake pad and disc life are realized when EBS assists normal brake system operation. The EBS is non-adjustable, and does not contain any user maintenance items. Contact your dealer for service.

SAFETY DECALS & LOCATIONS

How To Avoid CVT Drive Belt and Component Failure

CVT clutch and belt life can be dramatically extended by avoiding these common operating mistakes:

Causes CVT damage:	Solution:
Attempting to load the vehicle onto a truck bed or tall trailer in high gear.	Shift transmission to low gear during loading of the vehicle to prevent belt burning.
Starting out on a steep incline in high gear.	When starting out on steep inclines, use low gear.
Constant driving in high gear at low RPM, driving at just above clutch engagement RPM, or at low speed (approximately 3mph~6mph [5km/h~10 km/h]).	Low gear is highly recommended for cooler CVT operating temperatures and longer component life. Drive at a higher speed or use low gear more frequently.
Insufficient warm-up of CVT exposed to low ambient temperatures	Warm the engine before driving, the CVT drive belt will become more flexible and prevent belt burning.
Slow throttle and easy CVT engagement.	Use the throttle with purpose and effectively for efficient CVT clutch engagement.
Towing/pushing at low RPM/low ground speed.	Use low gear only.
Utility use/plowing snow, dirt, etc.	Use low gear only.
Heavy vehicle load operating at low speed	Use low gear only.

SAFETY DECALS & LOCATIONS

Causes CVT damage:	Solution:
Climbing over large objects from a stopped position.	Shift the transmission to low gear, and carefully use fast, brief, aggressive throttle application to engage the CVT. WARNING: Excessive throttle may cause loss of control and vehicle overturn.
Climbing over large objects from a stopped position.	Shift the transmission to low gear, and carefully use fast, brief, aggressive throttle application to engage the CVT. WARNING: Excessive throttle may cause loss of control and vehicle overturn.
Belt slipping from water or snow ingestion into the CVT system.	Drain the water from the CVT housing and dry the CVT if possible, or contact your dealer.
Overheating of the CVT components causes malfunction.	Contact your dealer for inspection and repair of the CVT components.

SAFETY DECALS & LOCATIONS

Dashboard Indicators and Operation

Indicators and Warnings

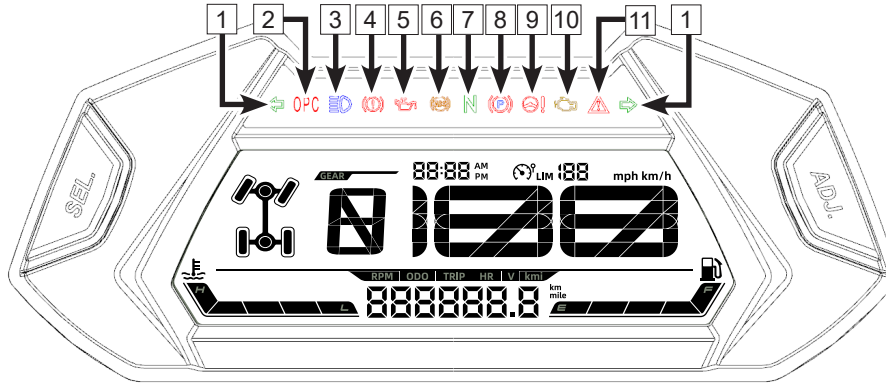

1	Tuning Indicators	5	Oil Pressure Alarm	9	EPS Failure Alarm
2	Operator presence control	6	ABS Fault Indicator	10	EFI indicator
3	High Beam Indicators	7	Neutral Indicator	11	Override indicator
4	Brake failure indicator	8	Park indicator		

SAFETY DECALS & LOCATIONS

1 Turning Indicators:

When the left turning switch is at the turning light position, the left turning indicator will flash. When the right turning switch is at the turning light position, the right turning indicator will flash.

2 Operator Presence Control :OPC

When the rider leaves the vehicle unattended but without parking, the indicator will be on and the alarm will sound simultaneously.

Ignition lock	ON				OFF		
RPM	≤1800		> 1800		/	/	/
Parking signal	Connected	Disconnected		Disconnected/ Connected	Disconnected	Disconnected	Connected
Seat switch signal	Connected/ Disconnected	Connected	Disconnected	Connected/ Disconnected	Disconnected	Connected	Connected/ Disconnected
Alarm method for leaves the vehicle unattended	OPC	OPC	OPC	OPC	OPC	OPC	OPC
	OPC not working	OPC is not working	OPC flashing and alarm	OPC is not working	OPC flashing and alarm, the instrument will be off after 5 minutes	OPC is not working	OPC is not working, the instrument will be off after 5 minutes

SAFETY DECALS & LOCATIONS

3 High Beam Indicator

This indicator will be on when the headlight switch is in this position

4 Brake Failure Indicator

Brake failure indicator will display when the brake fluid leaks or is lower than standard level.

5 Oil Pressure Indicator

When the indicator is on, the oil system may have malfunction occurs, service the vehicle as soon as possible.

SAFETY DECALS & LOCATIONS

6 ABS indicator (if equipped)

When the ABS working, the indicator will be off after the self-inspection.

When the ABS has fault occurs, the indicator will be on after the self-inspection.

7 Neutral Indicator

When the vehicle in neutral gear, the indicator will be on.

8 Park Indicator

This indicator will display when parking is engaged.

9 EPS Indicator

When the EPS system works normally but doesn't start, or the EPS system works failure, this indicator will be on.

10 EFI Indicator

When the EFI system has fault occurs, this indicator will be on.

11 Override Indicator

When the override function is on, this function will be on.

SAFETY DECALS & LOCATIONS

Indicators and Warnings

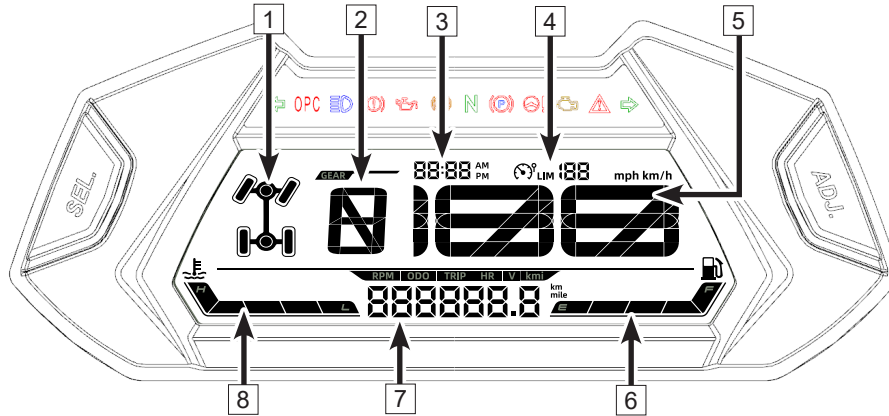

Dashboard

1	Drive Mode Display	4	Speed Limit Sign	7	Optional Information
2	Gear Display	5	Speedometer	8	Coolant temperature gauge
3	Clock indicator	6	Fuel Gauge		

SAFETY DECALS & LOCATIONS

1 Drive Mode Display

It will display the drive mode of the 2WD, 4WD or 4 WD-LOCK mode.

2 Gear Display

It will display the current gear.

3 Time Display

It will display the current time and switching between 12 hours format/24 hours format.

4 Speed Limit Sign

When turn on the ABS speed limit, here will display the current speed and speed limit logo.

Turn on:

Long press ADJ, here will display the actual speed and speed limit logo, which means the ABS speed limit is turned on.

Turn off:

Long press the ADJ again, the speed limit logo will disappear, which means the ABS speed limit is turned off.

Speed limit adjustment:

Press the ADJ button to adjust the limit speed. After adjustment, it will show the actual limit speed.

The limit speed can be cyclic adjusting within 55.9 mph~18.6mph (90km/h ~ 30km/h).

SAFETY DECALS & LOCATIONS

CAUTION

1. On the brightness control interface, press ADJ button to adjust it. On the other interfaces, press the button ADJ to adjust the target speed.
2. On the trip mileage interface, long press the button ADJ to reset the trip. On the other interfaces, long press the ADJ to turn on/turn off the ABS limit speed function.
3. Maximum speed limit value when the vehicle is powered off / or the ABS speed limit function is switched on by default.

5 Speedometer

It can be toggled to display the vehicle speed in Kilometers per hour (km/ h) or Miles Per Hour (MPH).

6 Fuel Gauge

Indicates the fuel level in the fuel tank. 'F' indicates full. 'E' indicates stand-by fuel. When the indicator enters the red area, the fuel must be added as soon as possible.

7 Optional Information

Using the button SEL and ADJ to switch the informations below:

Indicates the total mileage the vehicle has traveled. Press "SEL" button to toggle to TRIP meter, or engine hour, or EFI fault code, or battery voltage, or dashboard brightness.

8 Coolant Temperature Indicator

Here will display the current coolant temperature, "C" indicates the low temperature, "H" indicates the high temperature. Too low or too high is not normal, idle the vehicle when the temperature is too low, stop the vehicle when the temperature is too high to prevent the coolant from boiling. Keeping the coolant temperature within the normal range.

SAFETY DECALS & LOCATIONS

ABS

ABS is a safety system that prevents the wheel from locking when there is no side traction during straight driving.

With ABS, full braking force can be used in full braking and in situations with low road adhesion such as sandy, stagnant or smooth roads, will not cause the risk of wheel locking.

DANGER
Driving assistance can only prevent the vehicle from tipping within the physical limits, which may occur under extreme driving conditions, such as high baggage loading center of gravity, variable road conditions, and full braking on steep roads.

ABS works with two independent brake circuits (front and rear brakes). When the brake electronics control unit detects a locking tendency in a wheel, ABS begins to work by adjusting the brake pressure. The adjusting process can be felt through as a slight pulsing of the front brake lever or brake pedals.

When turning on the ignition switch, the ABS indicator will turn on and then turn off after the self-inspection. If the ABS indicator is still on after the self-inspection or it lights up during travel, the ABS must have some fault. If a fault occurs, the ABS will deactivate. The braking system is still working, but ABS is not available to prevent wheel lockup, so the wheels may lock during braking.

SAFETY DECALS & LOCATIONS

Dashboard Navigation / Settings / Adjustments

Item	Display	SEL / ADJ Button	Result
Metric / Standard Toggle	Speed/Distance	Long Press 'SEL'	Metric ↔ Standard Values
Distance/RPM/Item Toggle	Vehicle Odometer Trip Distance Engine RPM Engine Hour Battery Voltage Brightness Setting	Short Press 'SEL'	RPM-ODO-TRIP-HR- Dashboard brightness-V
Trip Distance Reset	Trip Distance	Long Press 'ADJ' in Odometer mode	Distance reset to zero
Clock - Hours Adjustment	Time	Short Press 'ADJ'	Incremental 1-12/1-24
Clock - Minutes Adjustment	Time	Long Press 'ADJ'	Incremental 00-59
Dashboard Brightness	LED 3-4-5-1-2-3	Short Press 'ADJ'	5 levels of brightness

OPERATION OF YOUR ATV

Operation of Your Vehicle

Break-In Period

The break-in period for your new Vehicle is very important. Careful treatment of a new engine will result in more efficient performance and longer life for the engine. Perform the following procedures carefully.

1. Select an open area that allows room to familiarize yourself with vehicle operation and handling.
2. Place the Vehicle on a level surface.
3. Fill the fuel tank with gasoline.
4. Check the engine oil level. Add the recommended oil if necessary to maintain the oil level between the minimum and maximum indicators on the dipstick.
5. Position yourself in the operating position on the vehicle and start the engine. Allow the engine to idle for a short period before operating.
6. Press the foot brake, select the desired gear, and then release the foot brake.
7. Apply throttle. Drive slowly at first, varying throttle positions not more than $\frac{1}{2}$ throttle for 10 hours or 100 miles, then another 10 hours or 100 miles of not more than $\frac{3}{4}$ throttle (whichever interval arrives first). Do not operate at sustained idle or sustained wide open throttle.
8. Do not pull or carry any loads during the break-in period.
9. At the end of the break-in period, change the oil and filter (20hrs or 200 miles/320km).

OPERATION OF YOUR ATV

⚠ CAUTION

During the break-in period:

- Do not load or tow cargo.
- Do not operate at sustained full throttle. Damage to engine parts or decrease engine life may result if excessive wide open throttle is used during the first 20 hours of use.
- Do not run engine with throttle over 1/2 open during the first 10 hours (or 100 miles/160km) of use.
- Do not run engine with throttle over 3/4 open during the first 10 to 20 hours (or the second 100 miles/160km) of use.
- Use of any oil other than those recommended may cause serious engine damage. Recommends the use of 5W-40 for 1-cylinder 4-stroke engines. Changing engine oil viscosity to 10W-40 or 15W-40 due to hot environments is acceptable. Reference the chart below for ambient temperature and viscosity choice.

Recommended Engine Oil Viscosity

Oil Viscosity				15W-40				
				10W-40				
				5W-40				
F°	-22	-4	14	32	50	68	86	104
C°	-30	-20	-10	0	10	20	30	40

OPERATION OF YOUR ATV

Pre-Ride Inspection

Perform the following procedures before operation:

1. Fill the fuel tank with gasoline.
2. Place the vehicle on a level ground to check the engine oil level. Add recommended engine oil if necessary to maintain the oil level between the minimum and maximum level marks of the dipsticks.
3. Drive slowly at first. Select an open area that allows room to familiarize yourself with vehicle operation and handling.
4. Vary throttle positions. Do not idle the vehicle for long time.
5. Perform regular checks on fluid levels, controls and items outlined on the daily pre-ride inspection checklist.
6. Pull the load under the maximum weight requirement.
7. During the break-in period, change both the oil and oil filter at 20 hours or 320km .

WARNING

If a proper inspection is not done before each use, severe injury or death could result. Always inspect the vehicle before each use to ensure it is in proper operating condition.

OPERATION OF YOUR ATV

Starting the Engine

WARNING

Engine exhaust contains poisonous carbon monoxide and can cause loss of consciousness resulting in severe injury or death. Never run an engine in an enclosed area.

CAUTION

Operating the vehicle immediately after starting could cause engine damage. Allow the engine to warm up for several minutes before operating the vehicle.

Starting a Cold Engine

1. Verify the gear selector is shifted to the Parking or Neutral position.
2. Apply the foot brake.
3. Turn the engine stop switch and main key switch to “” (ON)
4. Verify the throttle is completely closed, then push the start switch on the left-hand control.
5. Once the engine starts, continue to warm the engine for a short period before operating the vehicle.

OPERATION OF YOUR ATV

NOTE

- When the gear selector is in neutral position,if indicator light on dashboard does not come on,ask your dealer to inspect its electric circuit or adjust gear-shifting system.
- Engine can be started in any gear if rear brake pedal is applied. However it is recommended to shift into neutral or park before starting the engine.
- Completely close the throttle and start the engine by pushing the start switch.
- Do not activate the starting system more than 10 seconds on each attempt. If the engine fails to start, release the start switch, pause a few seconds before the next attempt, then push the start switch again. Each attempt should be as short as possible to preserve battery energy.
- If the battery is discharged, remove the battery to recharge.
- Continue warming up the engine until it idles smoothly before starting the Vehicle.

CAUTION

See the“Break-In Period”section before operating the engine for the first time.

OPERATION OF YOUR ATV

Gear Selector Operation

Shifting

CAUTION

To avoid transmission damage, return the throttle to the closed position, stop the vehicle, and apply the foot brake before shifting.

NOTE

Low gear is the preferred transmission gear selection for all forward motion other than prolonged high speed travel.

Shifting out of Park

1. Verify the throttle is closed.
2. Apply the foot brake.
3. Shift to the desired gear by moving the gear selector along the shift guide.

Shifting: Neutral to High Gear

1. Verify the throttle is closed and the vehicle is stopped completely.
2. Apply the foot brake.
3. Shift to 'H' by moving the gear selector along the shift guide.

Shifting: High Gear to Low Gear

1. Verify the throttle is closed and the vehicle is stopped completely.
2. Apply the foot brake.
3. Shift to 'L' by moving the gear selector along the shift guide.

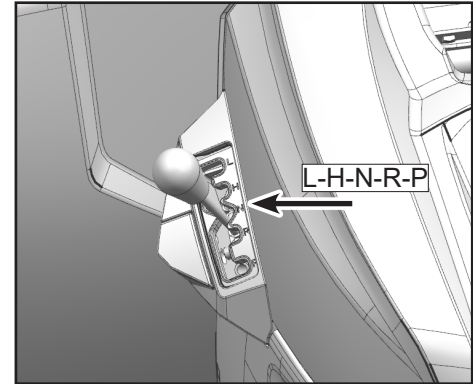

OPERATION OF YOUR ATV

Shifting: Low Gear to High Gear

1. Verify the throttle is closed and the vehicle is stopped completely.
2. Apply the foot brake.
3. Shift to 'H' by moving the gear selector along the shift guide.

Shifting: to Reverse Gear

1. Verify the throttle is closed and the vehicle is stopped completely.
2. Apply the foot brake.
3. Shift to 'R' by moving the gear selector along the shift guide.
4. Check behind you for people or obstacles, then release the rear brake pedal.
5. Apply the throttle lever gradually and continue to watch behind you while moving backward.

WARNING

When you shift into reverse, make sure there are no obstacles or people, and the area is safe behind you. When it is safe to proceed, go slowly.

Shifting: Reverse to Park

1. Verify the throttle is closed and the vehicle is stopped completely.
2. Apply the foot brake.
3. Shift to 'P' by moving the gear selector along the shift guide.

OPERATION OF YOUR ATV

NOTE

The gear selector must not be shifted into reverse gear without applying the foot brake.

The gear shift indicators should display corresponding to the actual gear position, if the indicator does not display, ask your dealer to inspect the vehicle electrical circuit or adjust the gear shifting system.

Due to the synchronizing mechanism in the engine, an indicator may not display until Vehicle starts moving.

Do not use high gear for continuous slow speed travel or towing, as this can lead to excessive heating of the clutch system, which may damage components.

OPERATION OF YOUR ATV

Hauling and Towing Cargo

Your vehicle is equipped with front and rear cargo racks, and a hitch receptacle for towing. Follow these guidelines for hauling and towing of cargo:

WARNING

Overloading the vehicle or carrying or towing cargo improperly can alter vehicle handling and may cause loss of control or brake instability. Always follow these precautions when hauling cargo:

- Never exceed the stated load capacity for this vehicle.
- Reduce speed when hauling or towing loads.
- When operating over rough or hilly terrain, reduce speed and cargo to maintain stable driving conditions.
- Weight distribution on the front and rear racks should be as far forward and as low as possible. Carrying a high load raises the center of gravity and creates an unstable operating condition. Reduce load weight when the cargo center of gravity is high. When handling off-centered loads that cannot be centered, secure the load and operate with extra caution.
- All loads must be secured before operation. Unsecured loads may shift and create unstable operating conditions, which could result in loss of control of the vehicle.

OPERATION OF YOUR ATV

- When operating with loads extending beyond the rack. Stability and maneuverability may be adversely affected, causing the machine to overturn.
- Carrying a load on only the front rack or the rear rack may cause an imbalanced condition and increases the possibility of vehicle overturn. Balance loads proportionally between the front rack and the rear rack, but do not exceed the stated load capacity.
- Use extreme caution when applying brakes with a loaded vehicle. Avoid terrain or situations that may require backing downhill.
- Always attach to the towable using the hitch point. Never exceed the recommended tongue weight.
- While towing, the vehicle should never exceed 10 mph (16 km/h) while towing a load on a level surface. Vehicle speed should never exceed 5mph (8 km/h) when towing loads in rough terrain, while cornering, or while ascending or descending a hill.
- Do not obstruct the headlight when loading the front rack.
- Always use low gear while towing to avoid clutch wear and belt issues.
- Using chains, straps, rope or other materials to tow objects is not recommended, as these items could get caught in the rear wheels, resulting in vehicle damage or personal injury.

OPERATION OF YOUR ATV

Load Distribution

Your vehicle has been designed to carry or tow a certain amount of load. Always read and understand the load distribution warnings listed on the warning labels, and never exceed the specified weights. Cargo weight should be mounted as low as possible. When operating over rough or hilly terrain, reduce speed and cargo to maintain stable driving conditions.

If a trailer is used behind the vehicle make sure that its hitch is compatible with the one on the vehicle. Make sure the trailer is horizontal with the vehicle. (In some instances a special extension may have to be installed on the vehicle hitch). Use security chains or cables to secure the trailer with the vehicle.

This vehicle may require additional stopping distance if hauling heavy loads, especially on inclined surfaces and when a passenger is on board. Improperly loading a trailer may cause loss of control. Respect the recommended maximum hauling capacity and maximum tongue load. Make sure there is at least some weight on the tongue.

Always make sure load is evenly distributed and safely secured on the trailer; an evenly balanced trailer is easier to control. Always put the shift lever to L (low range) for hauling a trailer in addition to providing more torque, operating in low range helps account for the increased load on the rear tires.

When stopped or parked, block the vehicle and trailer wheels from possible movement. Use caution when disconnecting a loaded trailer; it or its load may topple on you or others. When hauling a trailer, respect the following maximum hauling capacity.

**OPERATION OF YOUR ATV
MAXIMUM HAULING CAPACITY**

TRAILER LOAD ALLOWED	TONGUE WEIGHT ALLOWED	NOTE	
260 kg	25 kg	Trailer without brakes	Includes trailer and trailer load. Ensure to properly load the trailer so that tongue is always pushing on hitch support and not pulling on hitch ball.
NOTE: Includes trailer and trailer load. Ensure to properly load the trailer so that tongue is always pushing on hitch support and not pulling on hitch ball.			

 WARNING

Stay clear from the area between vehicle and trailed vehicle.

 WARNING

Strictly follow the instructions outlined in the operator s manual of the mounted or trailed machinery or trailer, and not to operate the combination vehicle - machine or vehicle - trailer unless all instructions have been followed.

OPERATION OF YOUR ATV

WARNING

When the trailer load approaches 882 lb. (400 kg) and the vehicle riding on a flat road, to ensure safety and reduce the vehicle getting damaged. The following measures should be taken:

Vehicle unloaded.

Switch to the 4WD.

Reduce the speed to under 9 mph (15 km/h).

Use the low gear to increase traction and stability.

WARNING

LOW GEAR is the preferred transmission gear selection when:

- Constant driving speeds are lower than 9 mph (15 km/h)
- Driving on level road surfaces, and the vehicle is carrying/towing more than 260kg
- Driving on muddy or rough road surfaces, and the vehicle is carrying/towing more than 260kg

OPERATION OF YOUR ATV

Intended Use

The vehicle is designed solely for use in agricultural or similar operations. Use in any other way is considered as contrary to the intended use. Compliance with and strict adherence to the conditions of operation, service, and repair as specified by the manufacturer, also constitute essential elements of the intended use. The vehicle should be operated, serviced, and repaired only by persons who are familiar with its particular characteristics and who are acquainted with the relevant safety procedures. Accident prevention regulations, all other generally recognized regulations on safety and occupational medicine, and all road traffic regulation must be observed at all times. Any arbitrary modifications carried out to this vehicle may relieve the manufacturer of liability for any resulting damage or injury. The agricultural vehicles can not be used in conditions which may cause the risk of contact with hazardous substances, e.g. spraying of pesticides. In addition, the agricultural vehicles also can not used in conditions which may risk of falling and penetrating objects.

OPERATION OF YOUR ATV

Hauling a Load

(If equipped with hitch)

Never pull a load by attaching it to the cage. It can cause the vehicle to tip stalled to pull a load.

In an emergency situation, use the recovery hook to recover a stuck vehicle.

When pulling loads with a chain or cable, ensure that there is no slack before starting and maintain tension while pulling.

When pulling loads with a chain or cable, be sure to brake progressively. The inertia of the load could lead to an impact.

When hauling a load, respect the maximum hauling capacity. See PULLING A TRAILER subsection.

 WARNING
--

Slack can cause the chain or cable to break and snap back.
--

When pulling another vehicle, be sure that someone is controlling the pulled vehicle. They must brake and steer to prevent the vehicle from going out of control.

Reduce your speed when hauling a load and turn gradually. Avoid hills and rough terrain. Never attempt steep hills. Allow more distance for braking, especially on inclined surfaces and when a passenger is on board.

Be careful not to skid or slide.

Accessories and Modifications

If no such attachment points are foreseen, the operator's manual shall prohibit the installation of a front end loader.

This T3 has not attachment points for front end loader. Do not install front loader.

FOR MORE INFORMATION ABOUT Vehicle SAFETY, PLEASE CONTACT WITH YOUR DEALER.

OPERATION OF YOUR ATV

Where a designated attachment point is provided on the towbar:

Either

a) Pass the cable through the attachment point and clip it back on itself (FIG.1)

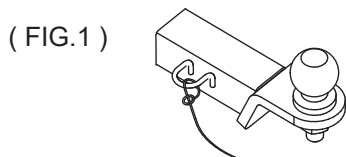

Or:

b) Attach the clip directly to the designated point (FIG.2). This alternative must be specifically permitted by the trailer manufacturer since the clip may not be sufficiently strong for use in this way.

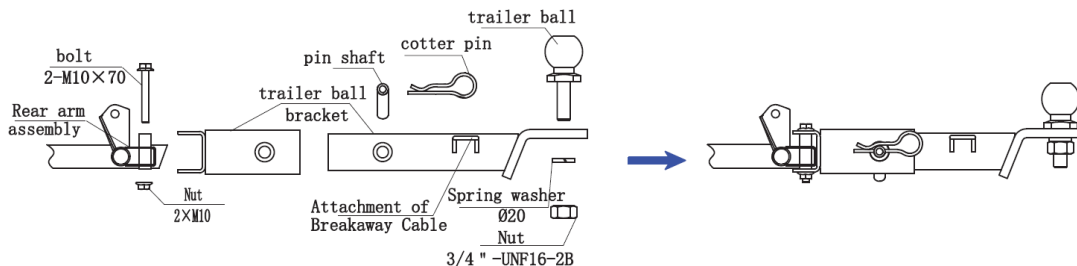
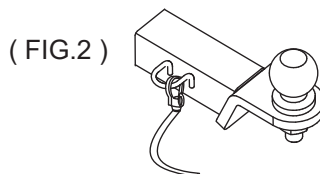

OPERATION OF YOUR ATV

Driving Safely

Responsibilities of the operator

As the operator of this vehicle, your common sense, judgment, and abilities are the only factors that will prevent injury to yourself, to others around you, and/or damage to the vehicle or environment.

Recreational, group, and distance riding

Always keep a safe distance from other riders ahead of you and behind you when riding in a group. Never operate carelessly or make unexpected maneuvers with other vehicles close by. Stay on designated trails and riding areas, and discourage others from operating in unauthorized locations.

OPERATION OF YOUR ATV

Practice

The driving procedures described in this manual should be practiced at slow speed many times in a large area with no obstacles. If an incorrect technique is used, your vehicle may continue to go straight. If the vehicle does not turn, stop and practice the procedure again. If the riding surface is slippery or loose, it may help to transfer more of your weight to the front wheels by moving forward on the seat. Once you have learned the proper techniques, you should be able to perform maneuvers at higher speeds or in tighter curves.

Improper driving procedures such as abrupt throttle changes, excessive braking, incorrect body movements, or too much speed for the sharpness of the turn may cause the Vehicle to tip. If the Vehicle begins to tip over to the outside while negotiating a turn, lean more to the inside. It may also be necessary to gradually let off on the throttle and steer to the outside of the turn to avoid tipping over.

Remember: Avoid higher speeds until you are thoroughly familiar with the operation of your Vehicle.

NOTE

Low gear is the preferred transmission gear selection for all forward motion other than prolonged high speed travel. Do not use high gear for continuous slow speed travel or towing, as this can lead to excessive heating of the clutch system, which may damage components.

OPERATION OF YOUR ATV

Driving Procedures

1. Sit upright with both feet on the footrests and both hands on the handlebars.
2. Start the engine and allow it to warm up, apply the brakes, then shift the transmission into gear.
3. Check your surroundings and determine your path of travel.
4. Release the brakes.
5. Slowly depress the throttle with your right thumb and begin driving. Vehicle speed is controlled by the amount of throttle opening.
6. Drive slowly. Practice maneuvering and using the throttle and brakes on level surfaces.

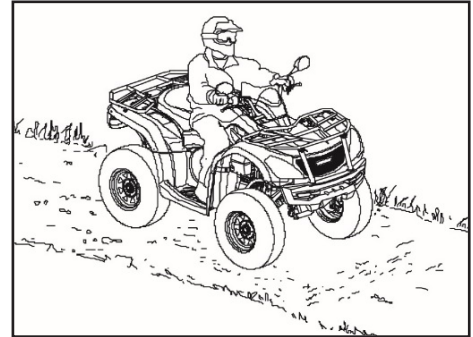

OPERATION OF YOUR ATV

Making Turns

To make a turn, steer in the direction of the turn, leaning your upper body to the inside of the turn while supporting your weight on the outer footrest. This technique alters the balance of traction between the wheels, allowing turn to be made smoothly. The same leaning technique should be used for turning in reverse.

NOTE

Practice making turns at slow speeds before attempting to turn at faster speeds.

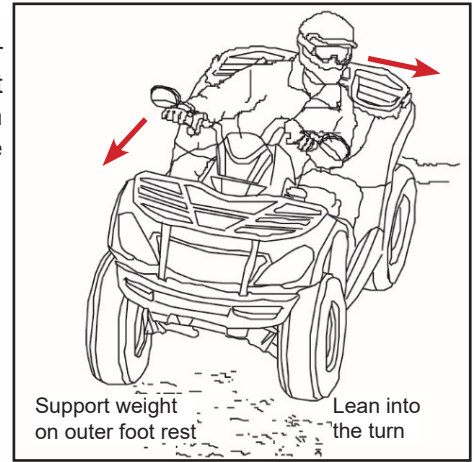

⚠️ WARNING

Turning at sharp angles or at excessive speeds can result in vehicle overturn and lead to serious injury. Avoid turning at sharp angles. Never make turns at high speeds.

OPERATION OF YOUR ATV

Vehicle turning dynamics

To achieve maximum traction while operating in 2WD or 4WD, the two rear wheels perform as one axle and turn together at the same speed. Furthermore, when operating in 4WD-LOCK mode, the front wheels will also turn together at the same speed. Therefore, unless the wheel on the inside of the turn is allowed to slip or lose some traction, the Vehicle will resist turning. The special turning technique described in this manual must be used to allow the Vehicle to make turns quickly and easily. It is essential that this skill be learned first at low speed.

WARNING

Always follow proper procedures for turning as described in this Owner's Manual. Practice turning at low speeds before attempting to turn at faster speeds. Do not turn at speeds too fast for your skills or the conditions. Operate at a slow speed and allow extra time and distance for maneuvers when in 4WD - LOCK (DIFF. LOCK).

As you approach a curve, slow down and begin to turn the handlebars in the desired direction. As you do so, put your weight on the footboard to the outside of the turn (opposite your desired direction) and lean your upper body into the turn. Use the throttle to maintain an even speed through the turn. This maneuver will let the wheel on the inside of the turn slip slightly, allowing the Vehicle to make the turn properly.

Turning on curves

As you approach a curve, slow down and begin to turn the handlebars in the desired direction. As you do so, put your weight on the foot board to the outside of the turn (opposite the desired direction) and lean your upper body into the turn. Use the throttle to maintain an even speed through the turn. This maneuver will let the wheel on the inside of the turn slip slightly, allowing the Vehicle to maneuver the turn properly.

OPERATION OF YOUR ATV

Driving in reverse

To operate in reverse:

1. Ensure the throttle is closed and the vehicle is stopped completely.
2. Apply the foot brake, then shift the transmission into reverse gear.
3. Check for obstacles or people behind the vehicle.
4. When it's safe to proceed, release the brakes, slowly press the throttle with your right thumb, and back slowly. Vehicle speed is controlled by the amount of throttle opening.

NOTE

Your Vehicle is equipped with a reverse speed limiter. The override button cannot be used. Do not operate at wide open throttle. Open the throttle just enough to maintain a desired speed.

Follow these precautions when operating in reverse:

- Always avoid backing downhill.
- Back slowly.
- When in reverse, apply the brakes lightly for stopping.
- Avoid turning at sharp angles in reverse.
- Never open the throttle suddenly while backing.

WARNING

Failure to use caution when operating in reverse can result in serious injury or death.

OPERATION OF YOUR ATV

Driving on slippery surfaces

Whenever driving on slippery surfaces such as wet trails, loose gravel, sand, or during freezing weather, follow these precautions:

- Slow down when entering slippery areas.
- Maintain a high level of alertness, reading the trail in front of you as you drive. Avoid quick, sharp turns which can cause skids.
- Correct a skid by turning the handlebars in the direction of the skid and shifting your body weight forward.
- Driving with 4WD engaged can assist in controlling the vehicle in slippery areas.

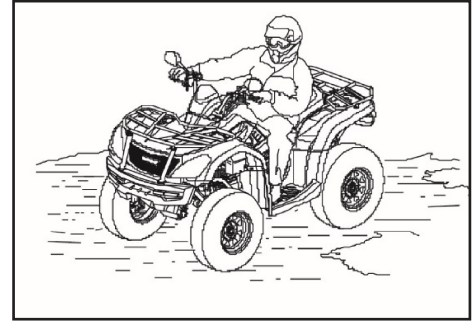

⚠ CAUTION

Severe damage to drive train may occur if 4WD is engaged while the wheels are spinning. Always engage 4WD when the wheels are at rest.

⚠ WARNING

Failure to exercise care when operating on slippery surfaces can result in loss of tire traction and loss of control, an accident, and serious injury or death. Never apply the brakes during a skid. Do not operate on excessively slippery surfaces. Always reduce speed and use additional caution.

OPERATION OF YOUR ATV

Driving on rough terrain

Whenever driving on rough surfaces such as trails with large rocks or other obstacles, follow these precautions:

- Slow down when encountering rough terrain.
- Maintain a high level of alertness, reading the trail in front of you as you drive. Avoid quick, sharp turns which can cause a loss of control.
- Shift your body weight to counteract the weight of the vehicle if it tips to one side.
- Driving with 4WD or 4WD-LOCK engaged can assist in controlling the vehicle.



Driving over obstacles

Be alert! Learn to look ahead and to read the terrain as you drive. Be constantly alert for hazards such as logs, rocks, and low hanging branches.

Never attempt to cross over an obstacle higher than the ground clearance of the vehicle.

⚠️ WARNING

Severe injury or death can result if your vehicle comes in contact with obstacles. Travel with caution on unfamiliar terrain.

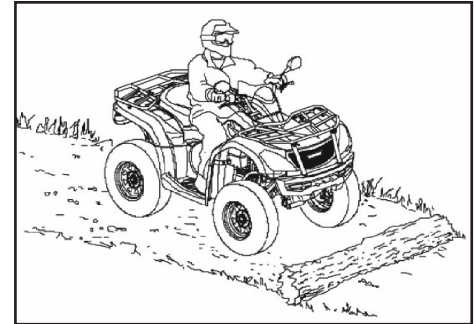

OPERATION OF YOUR ATV

Driving through water

Your Vehicle can operate through water with a maximum recommended depth equal to the bottom of the footrests. Follow these procedures when operating through water:

- Determine water depths and current before crossing.
- Choose a crossing where both banks have gradual inclines.
- Proceed slowly, avoiding rocks and obstacles if possible.
- After crossing, dry the brakes by applying light pressure to the lever until braking action is normal.

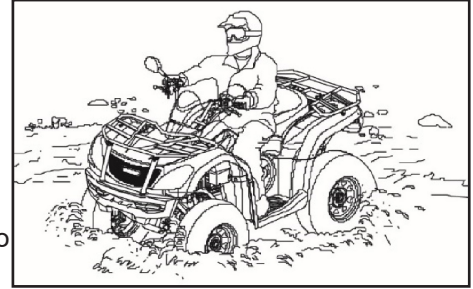

⚠️ WARNING

Avoid operating the vehicle through deep or fast-flowing water. If you cannot avoid water that exceeds the recommended maximum depth, go slowly, balance your weight carefully, avoid sudden movements, and maintain a slow and steady forward motion. Do not make sudden turns or stops, and do not make sudden throttle changes.

OPERATION OF YOUR ATV

Drying the CVT system after submersion

If water has been ingested into the CVT housing, the drive belt will likely slip and poor performance will result. To expel water and dry the CVT housing; Drain the CVT housing, place the vehicle in neutral, and raise the engine rpm for several minutes to dry the CVT components. Release the throttle and shift into low gear, then test the performance of the vehicle. Repeat as necessary until you are satisfied all the water has been expelled. Contact your dealer if vehicle performance issues continue.

NOTE

After running the vehicle in water, it is critical to have the vehicle serviced as outlined in the maintenance schedule. The following areas need special attention: engine oil, front and rear gear cases and all grease locations. If your vehicle becomes immersed, and it's impossible to take it to your dealer before starting it, follow the steps described in this manual to remove water from the air box and engine.

CAUTION

Major engine damage can result if the vehicle is not thoroughly inspected after operation in water. If water has been ingested into the CVT housing, follow the procedure in this manual for drying out the CVT clutch system. Have the vehicle serviced by your dealer promptly if your vehicle becomes immersed or stalls in water that exceeds the footrest level. It is important to contact your dealer for service before starting the engine, as water may have been ingested in the air box and engine.

OPERATION OF YOUR ATV

Driving Uphill

Whenever traveling uphill, follow these precautions:

- Always travel straight uphill.
- Avoid steep hills (20° maximum).
- Keep both feet on the footrests.
- Shift your weight forward.
- Maintain a steady rate of speed and throttle opening.
- Remain alert and be prepared to take emergency action. This may include quick dismounting of the vehicle.

If all forward speed is lost:

Keep your weight uphill and release the throttle.

Apply the front brake. When fully stopped, apply rear brake as well, then shift gear selector into park position.

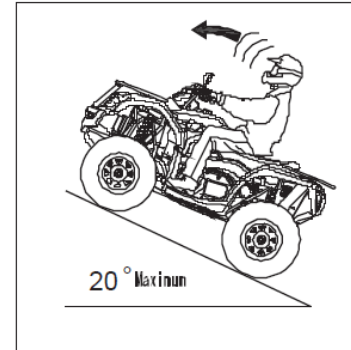

OPERATION OF YOUR ATV

If the Vehicle begins rolling backwards:

Keep your weight uphill. Never apply engine power. Never apply the foot brake while rolling backwards.

Apply the front brake. When fully stopped, apply the rear brake and shift the gear selector into park position.

Dismount on uphill side, or to either side if Vehicle is pointed straight uphill. Turn the Vehicle around and remount following the procedure described in the manual.

WARNING

Braking and handling are greatly affected when operating in hilly terrain. Improper procedure could cause loss of control or overturn and result in serious injury or death.

Avoid climbing steep hills (20° maximum).

Use extreme caution when operating on hills, and follow proper operating procedures outlined in the owner's manual.

OPERATION OF YOUR ATV

Sidehilling

⚠️WARNING

Improperly crossing hills or turning on hills can result in loss of control or vehicle overturn, resulting in severe injury or death. Avoid crossing the side of a hill when possible. Follow proper procedures as outlined in the owner's manual.

Sidehilling can be a dangerous type of driving and should be avoided if at all possible. If you do enter into a situation where sidehilling is necessary, follow these precautions:

- Slow down.
- Lean into the hill, transferring your upper body weight toward the hill while keeping your feet on the footrests.
- Steer slightly into the hill to maintain vehicle directions.

⚠️CAUTION

If the vehicle begins to tip, quickly turn the front wheel downhill, if possible, or dismount on the uphill side immediately!

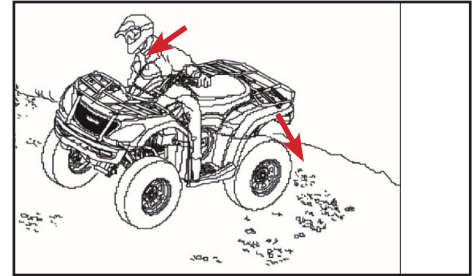

OPERATION OF YOUR ATV

Driving downhill

When traveling down a hill, follow these precautions:

- Never operate on hills over 22 degrees incline or hills too steep for your abilities.
- Slow down.
- Shift your weight to the rear of the vehicle.
- Always travel directly downhill.
- Utilize the engine braking function and apply the foot brake lightly to aid in slowing. Familiarize yourself with operation of these braking functions during downhill descents.
- Driving with 4WD or 4WD-LOCK engaged can assist in controlling the vehicle.

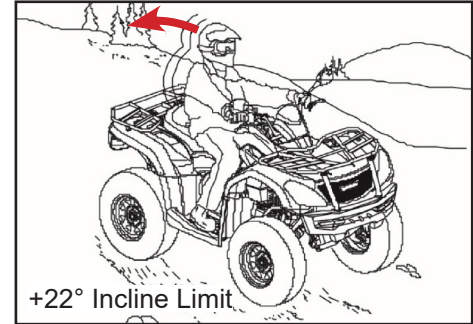

⚠️ WARNING

Excessive downhill speed can cause loss of control and lead to serious injury or death. Always reduce speed when traveling downhill.

OPERATION OF YOUR ATV

Turning Around on a Hill

One maneuver that can be used when it's necessary to turn around if stranded while climbing a hill is the K-turn:

1. Release the throttle, then apply the hand and foot brake while keeping your body weight uphill.
2. Shift the gear selector lever to the low gear position. Shut off the engine.
3. Keeping the hand brake applied, dismount on the right side of the vehicle if the vehicle is pointed straight uphill.

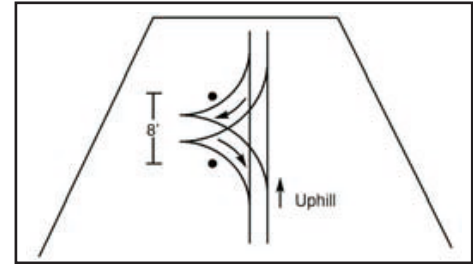

NOTE: Always dismount on the uphill side when the vehicle is pointed in a direction other than uphill.

4. Keeping the hand brake applied, move uphill (in front) of the vehicle, and pull on the right handle bar to turn the steering full left (front brake will now be closest to you).
5. Slowly release the hand brake lever, and use it to control the descent of the vehicle, which will roll downhill and to your right (as viewed from the vehicle front) until it's pointing across the hill or slightly downward. The vehicle's rolling weight is neutralized, and vehicle remount is now possible.
6. Remount the vehicle from the uphill side and shift the gear selector lever to the parking position, keeping your body weight uphill. Keep the hand brake or foot brake applied at all times if possible.
7. Restart the engine. Press the foot brake, and shift the gear selector lever to low gear position.
8. Release the brakes and proceed slowly downhill, controlling speed with the brakes, until the vehicle is on more level ground.

OPERATION OF YOUR ATV

Parking on an incline

Avoid parking on an incline if possible. If it's unavoidable, follow these precautions:

- Turn the engine off.
- Place the gear selector to parking position.
- Always block the rear wheels on the downhill side. Refer to the illustration.

⚠ CAUTION

The rear output shaft is locked when the transmission is in the parking position.

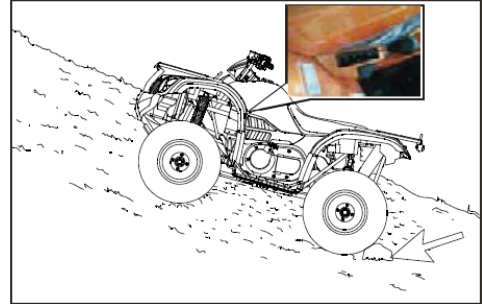

MAINTENANCE & LUBRICATION

Maintenance

Following the maintenance schedule in your owner's manual will help keep your vehicle in the safest, most reliable condition. Inspection, adjustment, and lubrication of important components are explained in the maintenance schedules.

Inspect, clean, lubricate, adjust, and replace parts as necessary. When inspection reveals the need for replacement parts, please use genuine parts available from your dealer.

Severe Use Definition

Defines severe vehicle use as:

- Frequent immersion in mud, water or sand
- Racing or race-style high RPM use
- Prolonged low speed, heavy load operation
- Extended engine idle
- Short trip, cold weather operation
- Vehicles used in commercial operations

For vehicles that are subjected to severe use, reduce all maintenance and service intervals by 50%.

NOTE

Periodic service and adjustments are critical. If you are not familiar with performing safe service and adjustment procedures, have a qualified dealer perform the required maintenance for you.

MAINTENANCE & LUBRICATION

NOTE

Pay special attention to the engine oil level during cold weather operation. A rise in engine oil level can indicate contaminants collecting in the oil sump or crankcase. Change oil immediately if the oil level begins to rise. Monitor the oil level, and if it continues to rise, discontinue use and determine the cause, or see your dealer.

Periodic Maintenance Schedule and Icon Key

Maintenance intervals in the following schedules are based upon average riding conditions and an average operating speed of approximately 12.4 mph (20 km/h). Vehicles subjected to severe or commercial use must be inspected and serviced more frequently.

The following icon keys are used to note special circumstances:

- ▶ = Severe Use Item. Reduce interval by 50% on vehicles subjected to severe use.
- = Have an authorized dealer perform repairs that involve this component or system.
- = Emissions related components. Have an authorized dealer perform repairs that involve this component or system.

WARNING

Procedures marked as '■' means if repair is required, have an authorized dealer perform repairs that involve this component or system. Improperly performing the procedure could result in component failure and lead to serious injury or death.

MAINTENANCE & LUBRICATION

KEY POINTS OF LUBRICATION SCHEDULE:

Check all components at the intervals outlined in the Periodic Maintenance Schedule. Items not listed in the schedule should be lubricated at the general lubrication interval.

- Change lubricants more often under severe use, such as wet or dusty conditions.
- Use All Season Grease on pivot points.
- Lubricate every 500 miles (800 km), before long periods of storage, after pressure washing, or after submerging drive system.

Item	Lubricant	Method
Engine oil	SAE 10W-40 SAE 5W-40 / SAE 15W-40	Screw off, clean, insert and pull out dipstick to check oil level
Brake fluid	DOT4	Keep level between upper and lower lines
Front gear case oil	SAE80W-90 GL-5	Oil capacity: 6.8 oz. (200 mL)
Rear gear case oil	SAE80W-90 GL-5	Oil capacity: 7.8 oz. (250 mL)
Suspension pivots and drive train	All Season Grease	Grease gun - Pump grease until it begins to flow from the pivot point

MAINTENANCE & LUBRICATION

Pre-Ride Maintenance Checklist

Perform these inspections before operating the vehicle:

Item		Maintenance before operation			
		Hour	Calendar	Miles (km)	Remarks
■	Steering system	-	Pre-Ride	-	Visually inspect, test, or check components. Make adjustments and/or schedule repairs when required.
■	Throttle return	-	Pre-Ride	-	
	Front suspension and axles	-	Pre-Ride	-	
	Rear suspension and axles	-	Pre-Ride	-	
	Tires	-	Pre-Ride	-	
	Brake fluid level	-	Pre-Ride	-	
	Brake lever / foot brake function	-	Pre-Ride	-	
	Brake system function	-	Pre-Ride	-	
	Wheels / fasteners	-	Pre-Ride	-	
	Engine oil level	-	Pre-Ride	-	
▶	Air filter / Air box and connections	-	Pre-Ride	-	Visually inspect. Replace filter when dirty.

▶ = Severe Use Item. Inspect frequently on vehicles subjected to severe use.

■ = Have an authorized dealer perform repairs that involve this component or system.

● = Emissions related components. Have an authorized dealer perform repairs that involve this component or system.

MAINTENANCE & LUBRICATION

Item		Maintenance before operation			
		Hour	Calendar	Miles (km)	Remarks
▶	Air box sediment tube	-	Pre-Ride	-	Inspect. If deposits are visible, clean intake tubes, air box, and replace air filter.
▶	CVT sediment tube	-	Pre-Ride	-	Inspect. If deposits are visible, drain / clean the CVT or have it serviced by a dealer.
■	Headlight aim / General lighting and turn indicators (if equipped)	-	Pre-Ride	-	Inspect. Adjust or replace lights when necessary.
▶	Radiator	-	Pre-Ride	-	Inspect for mud or debris blocking airflow. Clean surfaces when necessary.

▶ = Severe Use Item. Inspect frequently on vehicles subjected to severe use

■ = Have an authorized dealer perform repairs that involve this component or system.

● = Emissions related components. Have an authorized dealer perform repairs that involve this component or system.

MAINTENANCE & LUBRICATION

Break-In Maintenance Checklist

Perform these maintenance items when the vehicle break-in is completed:

Item		Break-in Maintenance (Perform at the interval that arrives first)			
		Hour	Calendar	Miles (km)	Remarks
	General lubrication	20	-	200 (320)	Lubricate all grease points, pivots, cables, etc.
	Engine oil / oil filter / oil strainer	20	-	200 (320)	Change oil and filter. Clean oil strainer.
▶	Engine air filter	20	-	200 (320)	Inspect; replace if dirty; do not clean
■	Engine valve clearance	20	-	200 (320)	Check and adjust as necessary.
	Front / Rear gear case oil	20	-	200 (320)	Check level. Inspect for leaks.
	Coolant	20	-	200 (320)	Check level. Inspect for leaks.
▶	Brake pads	20	-	200 (320)	Inspect pad thickness.

▶ = Severe Use Item. Reduce interval by 50% on vehicles subjected to severe use.

■ = Have an authorized dealer perform repairs that involve this component or system.

● = Emissions related components. Have an authorized dealer perform repairs that involve this component or system.

MAINTENANCE & LUBRICATION

Item		Break-in Maintenance (Perform at the interval that arrives first)			
		Hour	Calendar	Miles (km)	Remarks
	Battery	20	-	200 (320)	Check terminals, clean, test battery condition if required.
■	Idle condition	20	-	200 (320)	Inspect for proper rpm. See dealer for service if out of spec or erratic.
■	Steering / Wheel Alignment	20	-	200 (320)	Inspect steering system. See dealer for service if wheel alignment is required.
▶	Foot brake / Hand brake	20	-	200 (320)	Inspect function. Adjust as necessary.
	Gear cases, CV shafts, Propshafts	20	-	200 (320)	Inspect for leaks.
	Engine hoses, gaskets and seals	20	-	200 (320)	Inspect for leaks.

▶ = Severe Use Item. Reduce interval by 50% on vehicles subjected to severe use.

■ = Have an authorized dealer perform repairs that involve this component or system.

● = Emissions related components. Have an authorized dealer perform repairs that involve this component or system.

MAINTENANCE & LUBRICATION

Periodic Maintenance Schedule

Perform these maintenance items when the vehicle break-in is completed:

Item		Periodic Maintenance Intervals (Perform at the interval that arrives first)			
		Hour	Calendar	Miles (km)	Remarks
▶	Brake pads	10	Monthly	100 (160)	Inspect pad thickness.
	Battery	20	--	200 (320)	Check terminals. Clean and test battery condition as necessary.
	Engine hoses, gaskets and seals	20	--	200 (320)	Inspect for leaks.
▶	Air filter	50h	--	500 (800)	Always inspect pre-ride. Inspect frequently if subjected to severe use. Replace if dirty. Do not clean.
▶	CVT air intake filter screen / filter	50h	--	500 (800)	Clean filter screen or filter, replace with new one if necessary.
▶	General lubrication	50h	3M	500 (800)	Lubricate all fittings, pivots, cables, etc.

▶ = Severe Use Item. Reduce interval by 50% on vehicles subjected to severe use.

■ = Have an authorized dealer perform repairs that involve this component or system.

● = Emissions related components. Have an authorized dealer perform repairs that involve this component or system.

MAINTENANCE & LUBRICATION

Item		Periodic Maintenance Intervals (Perform at the interval that arrives first)			
		Hour	Calendar	Miles (km)	Remarks
▶	Front gear case oil	100h	12M	1000 (1600)	Inspect level. Change yearly if hours or distance interval is not met.
▶	Rear gear case oil	100h	12M	1000 (1600)	Inspect level. Change yearly if hours or distance interval is not met.
▶	Engine oil / oil filter / oil strainer	100h	12M	1000 (1600)	Inspect for color change. Change if dirty and clean strainer. Change yearly if hours or distance interval is not met.
	Cooling system	50h	6M	500 (800)	Test coolant strength. Pressure test system yearly.

▶ = Severe Use Item. Reduce interval by 50% on vehicles subjected to severe use.

■ = Have an authorized dealer perform repairs that involve this component or system.

● = Emissions related components. Have an authorized dealer perform repairs that involve this component or system.

MAINTENANCE & LUBRICATION

Item		Periodic Maintenance Intervals (Perform at the interval that arrives first)			
		Hour	Calendar	Miles (km)	Remarks
▶	Radiator	50h	6M	500 (800)	Inspect; clean external surfaces. Clean more frequently if subjected to severe use.
■	Steering system	50h	6M	500 (800)	Inspect. Lubricate.
▶	Front suspension	50h	6M	500 (800)	Lubricate. Check fasteners.
▶	Rear suspension	50h	6M	500 (800)	Lubricate. Check fasteners.
▶	Gear shift	50h	1M	500 (800)	Inspect, lubricate, adjust as necessary.
▶ ■	Throttle body / throttle cable	50h	6M	500 (800)	Inspect. Clean carbon deposits. Inspect cable and lubricate frequently if subjected to severe use.

▶ = Severe Use Item. Reduce interval by 50% on vehicles subjected to severe use.

■ = Have an authorized dealer perform repairs that involve this component or system.

● = Emissions related components. Have an authorized dealer perform repairs that involve this component or system.

MAINTENANCE & LUBRICATION

Item		Periodic Maintenance Intervals (Perform at the interval that arrives first)			
		Hour	Calendar	Miles (km)	Remarks
▶ ■	CVT drive belt	100h	12M	1000 (1600)	Inspect. Replace as necessary. See dealer for service.
■	CVT drive and driven pulleys	100h	12M	1000 (1600)	Clean and Inspect pulleys. Replace worn parts. See dealer for service.
	Fuel filter and hoses	100h	24M	2000 (3200)	Inspect routing and condition. Replace filter and high-pressure hoses every 4 years.
	Cooling hoses	100h	--	1000 (1600)	Inspect routing and condition.
▶	Valve clearance	100h	--	2000 (3200)	Inspect and adjust as necessary. See dealer for service.

▶ = Severe Use Item. Reduce interval by 50% on vehicles subjected to severe use.

■ = Have an authorized dealer perform repairs that involve this component or system.

● = Emissions related components. Have an authorized dealer perform repairs that involve this component or system.

MAINTENANCE & LUBRICATION

Item		Periodic Maintenance Intervals (Perform at the interval that arrives first)			
		Hour	Calendar	Miles (km)	Remarks
●	Fuel system	100h	12M	500 (800)	Inspect fuel tank, cap, fuel pump and fuel pump relay.
	Spark plug	100h	24M	2000 (3200)	Inspect; Replace if worn or fouled.
■	Engine mounts	100h	12M	1500 (2400)	Inspect condition.
	Exhaust pipe and spark arrestor	100h	12M	500 (800)	Inspect. Clean spark arrestor.
▶	Wiring, fuses, connectors, relays, and cables	100h	12M	1000 (1600)	Inspect wire routing for wear, security. Apply dielectric grease as necessary to connectors subjected to water, mud, etc.

▶ = Severe Use Item. Reduce interval by 50% on vehicles subjected to severe use.

■ = Have an authorized dealer perform repairs that involve this component or system.

● = Emissions related components. Have an authorized dealer perform repairs that involve this component or system.

MAINTENANCE & LUBRICATION

Item		Periodic Maintenance Intervals (Perform at the interval that arrives first)			
		Hour	Calendar	Miles (km)	Remarks
▶ ■	Wheel bearings	100h	12M	1500 (2400)	Inspect for noise or looseness Replace as necessary.
▶	Safety Belts	100h	12M	2000 (3200)	Visually inspect belts and test latches. Clean latch mechanism more often if used in severe conditions.
	Coolant	200h	24M	4000 (6400)	Change coolant every 2 years if hours or distance interval is not met.
▶	Brake fluid	200h	24M	1000 (1600)	Inspect fluid for color change. Change fluid every two years.

▶ = Severe Use Item. Reduce interval by 50% on vehicles subjected to severe use.

■ = Have an authorized dealer perform repairs that involve this component or system.

● = Emissions related components. Have an authorized dealer perform repairs that involve this component or system.

MAINTENANCE & LUBRICATION

Item		Periodic Maintenance Intervals (Perform at the interval that arrives first)			
		Hour	Calendar	Miles (km)	Remarks
	Idle condition	--	12M	--	Inspect for proper rpm. See dealer for service if out of spec or erratic.
■	Steering / Wheel Alignment	--	12M	--	Inspect steering system. See dealer for service whenever steering parts or wheel alignment are required.
▶	Foot brake height	--	12M	--	Inspect. Replace brake pads or adjust height as required.

▶ = Severe Use Item. Reduce interval by 50% on vehicles subjected to severe use.

■ = Have an authorized dealer perform repairs that involve this component or system.

● = Emissions related components. Have an authorized dealer perform repairs that involve this component or system.

MAINTENANCE & LUBRICATION

Maintenance Procedures

Engine oil check

Always check and change the engine oil at the intervals outlined in the Maintenance Schedule.

1. Place the Vehicle on a level surface.
2. Start the engine and let it idle for (20~30) seconds. Stop the engine.
3. Wait a short period for the oil to settle.
4. Remove access cover **1** by grasping the lower right portion and pulling firmly.
5. Unscrew the oil dipstick **2** out and wipe off with a clean cloth.
6. Insert the dipstick into the oil filler hole. Do not reinstall it.
7. Remove the dipstick again and check the oil level indication. Maintain the oil level between the upper and lower indicators.
8. Reinstall the dipstick into the oil filler hole, hand-tighten it, and reinstall the access cover.

NOTE

Access cover grommets may come loose. Ensure they are in place before reinstalling the cover.

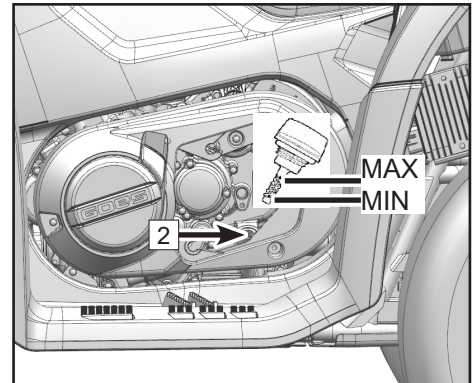
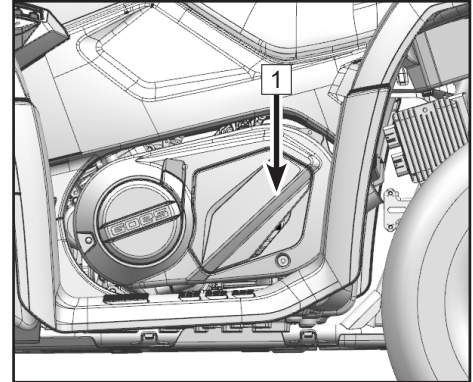

MAINTENANCE & LUBRICATION

Engine oil and filter change

1. Place the Vehicle on a level surface.
2. If the engine was running, wait a sufficient period for the oil to settle and cool.

Crankcase drain and sump filter service

3. Place an oil pan under the engine to collect the used oil.
4. Remove the engine oil drain bolt **1** and drain the oil from the crankcase.
5. Remove the crankcase sump cover fasteners **2** and filter cover **3**.
6. Remove the crankcase sump filter, wash it in solvent, dry it, and reinstall with the cover and fasteners. Tighten the fasteners to 7.3 ft-lb. (10 N•m).
7. Place a new sealing washer on the engine oil drain bolt, then assemble and tighten the drain bolt to 22 ft-lb. (30 N•m).

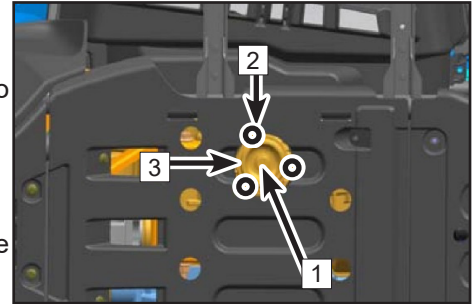

MAINTENANCE & LUBRICATION

Oil filter cartridge replacement

1. If necessary, remove the left cover panel to access the oil filter location. Remove the oil filter cover fasteners [4] and cover [5] from the crankcase.
2. Remove the oil filter cartridge [6] from the crankcase housing.
3. Install a new oil filter cartridge in the crankcase housing.
4. Inspect and verify the cover O-ring [7] is okay to reuse, and then install it into the groove of the crankcase housing correctly.
5. Install the oil filter cover and fasteners. Tighten the fasteners to 7.3 ft-lb. (10 N•m).
6. Add the specified amount of recommended engine oil, and then reinstall the engine oil dipstick and hand-tighten it.

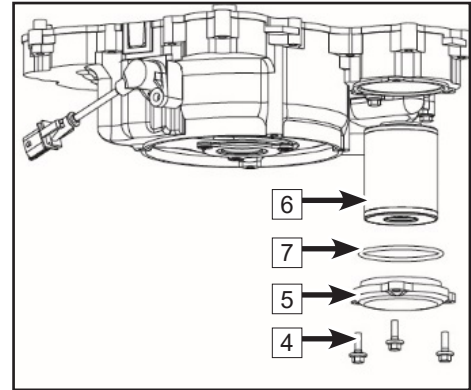

NOTE

In case of engine overhaul, oil should be added: 3.0 L;

With oil filter cartridge replacement, oil should be added: 2.8L.

7. Start the engine and allow it to warm up for several minutes. While warming up, check for oil leaks. If an oil leak is found, turn the engine off immediately and check for the cause.
8. Turn the engine off. Recheck the oil level and correct it if necessary.

MAINTENANCE & LUBRICATION

Rear gear case oil measurement

1. Place the vehicle on a level surface.
2. Remove the oil filler bolt [1] and check the oil level. The level should be up to the brim of the hole. If the level is low, add sufficient oil to raise it to the specified level.
3. Install the oil filler bolt and tighten it to 17 ft-lb. (25 N•m).

Rear gear case oil change

1. Place the vehicle on a level surface.
2. Place an oil pan under the gear case to collect the used oil
3. Remove the oil drain bolt [2] at the bottom of the gear case and drain the oil.
4. Install the oil drain bolt and tighten it to 17 ft-lb. (25 N•m).
5. Add sufficient oil to raise the level up to the brim of the hole.
6. Install the oil filler bolt and tighten it to 17 ft-lb. (25 N•m).
7. Check if any oil leaks. In case of any leakage, please find causes and solve it.

NOTE

Approximate rear gear case oil capacity: 8.4 oz. (250mL)
Be sure no foreign material enters into the rear gear case.

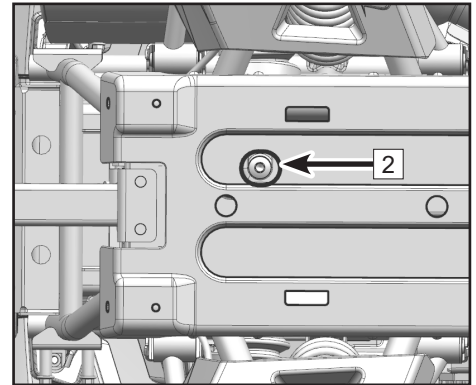
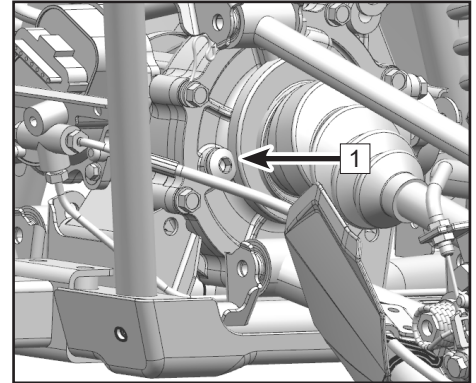

MAINTENANCE & LUBRICATION

Front gear case oil measurement.

1. Place the machine on a level surface.
2. Remove the oil filler bolt **2** and check the oil level. It should be up to the brim of the hole. If the level is low, add sufficient oil to raise it to the specified level.
3. Install the oil filler bolt and tighten it to the specified torque.

Front gear case oil change

1. Place the machine on a level surface.
2. Place a container under the front gear case to catch the oil.
3. Remove oil filler bolt and drain bolt **1** at the bottom of front gear case, and drain used oil.
4. Install the drain bolt and tighten it to the specified torque.
5. Fill the front gear case with oil.
6. Install the filler bolt **2** and tighten it to the specified torque.
7. Check for oil leaks. If oil leakage is found, check the cause.

NOTE

Oil filler bolt and drain bolt tightening torque: 17 ft-lb. (25 N•m).

Approximate front gear case oil capacity: 0.23 L

Be sure no foreign material enters the front gear case.

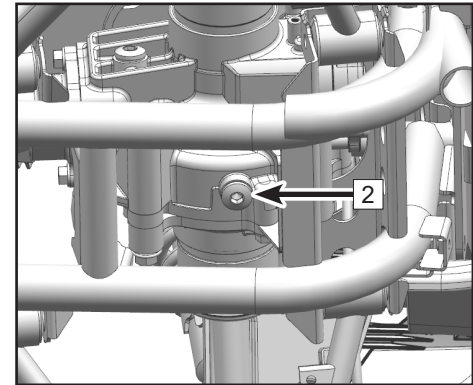
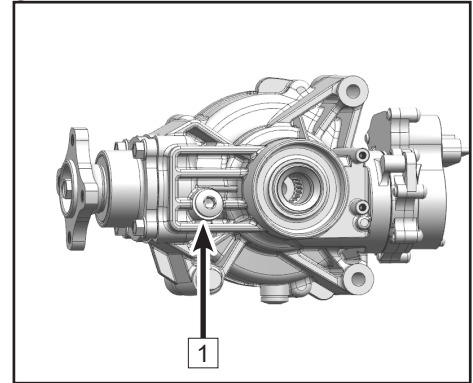

MAINTENANCE & LUBRICATION

Front access cover

Removal:

Grasp the access cover edge, pull upward to release the grommet pins, then remove the front access cover **A** by direction of front of vehicle.

Install: Insert the cover tabs into the corresponding holes on the body, then align the grommet pins and press down.

NOTE:

Remove front access cover, then inspection and maintenance can be done for the radiator assy, reservoir tank, relay box, and fuse.

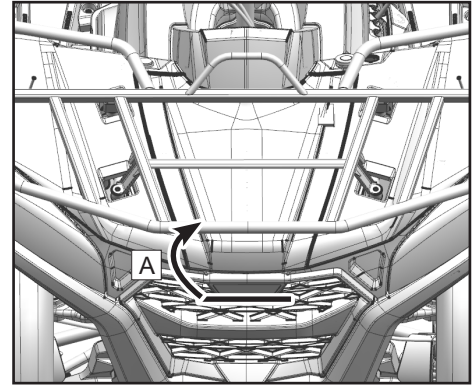

MAINTENANCE & LUBRICATION

Cooling system

Coolant level inspection

1. Place the Vehicle on a level surface.
2. Check the coolant level in the coolant reservoir when the engine is cold as the coolant level will vary with engine temperature.
3. If the coolant is at or below the lower limit mark, remove the access cover and the reservoir cap **1**, add coolant to the upper limit mark, install the reservoir cap, and then install the access cover.

NOTE

The coolant should be between the upper and lower limit marks.
Lowest capacity of coolant reservoir: 0.23 L

CAUTION

Hard water or salt water is harmful to the engine. You may use soft water if you can not get distilled water.

Attention

If water is added, have your dealer check the antifreeze content of the coolant as soon as possible. The radiator fan operation is completely automatic. It is switched on or off according to the coolant temperature in the radiator

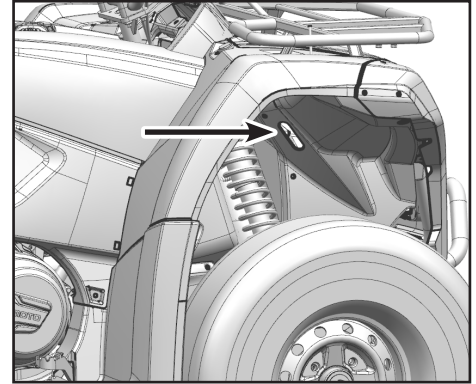

MAINTENANCE & LUBRICATION

Change the coolant

⚠ CAUTION

After running the engine, never remove the radiator cap immediately. Wait for the engine to cool down before removing the radiator cap. Hot coolant can cause serious burns.

1. Place the Vehicle on a level surface.
2. Remove the front access cover.
3. Remove the radiator cap [3].
4. Remove the coolant reservoir cap [2].
5. Place a container under the engine, and then remove:
 - The small engine left cover [4].
 - The engine left cover [5].
 - The coolant drain bolt [6]

Coolant will begin to drain from the system

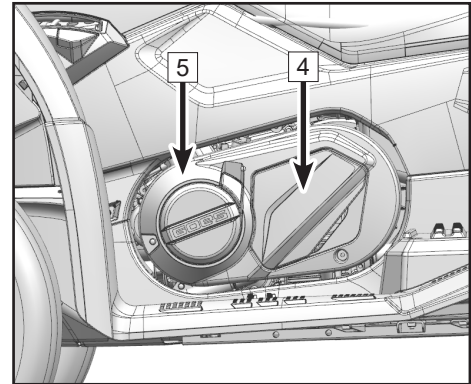
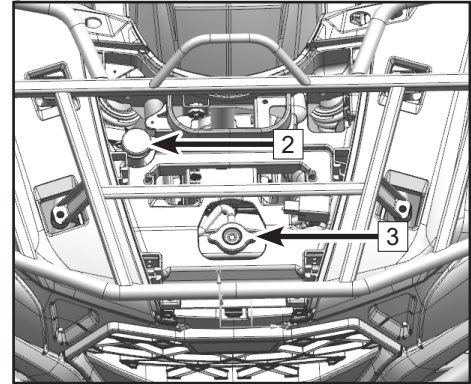

MAINTENANCE & LUBRICATION

6. Disconnect the hose from the coolant reservoir, and drain the coolant into a container.
7. After draining the system, thoroughly flush the system with clean tap water. Allow the water to drain completely from the coolant drain.
8. Replace the coolant drain bolt washer if it is damaged, then install and tighten the coolant drain bolt, but do not torque to specification.
9. Reinstall the coolant reservoir hose.
10. Fill the recommended coolant into the radiator until it is full.

NOTE

When filling coolant, at the same time loosen the coolant drain bolt **6** to draw out potential air bubbles inside the coolant hose until coolant flows out, then tighten the drain bolt to 7.3 ft-lb. (10 N•m).

11. Install the radiator cap.
12. Start the engine and let it idle for several minutes. Stop the engine and allow it to cool. Check the coolant level in the radiator. If it is low, add more coolant until it reaches the top of the radiator. Repeat as necessary.
13. Fill the coolant reservoir with coolant up to the upper limit.

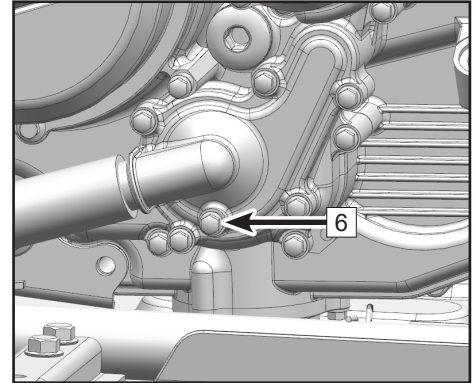

MAINTENANCE & LUBRICATION

14. Install the coolant reservoir cap and check for coolant leaks. If any leaks are found, have your dealer check the cooling system.
15. Reinstall:
 - The engine left cover. Tighten the fasteners to 7.3 ft-lb. (10 N•m).
 - The small engine left cover
 - The front access cover

NOTE

Recommended antifreeze:

Any high quality ethylene glycol antifreeze containing corrosion inhibitors for aluminum engines. Antifreeze and water mixing ratio: 1: 1

Coolant capacity: 2.1 qt. (2.27 L)

Coolant change: 2.0 qt. (1.89 L)

Coolant reservoir capacity: 0.24 mL. ~ 0.43 mL

Cleaning

Cleaning the external surfaces of the radiator if it is covered with mud or debris will ensure it continues to efficiently cooling the engine. Use only low pressure water to clean the radiator. High pressure washers can damage components. Ensure that the water can flow can flow freely through the radiator fins. This is a sign that cooling air will be allow to pass through.

MAINTENANCE & LUBRICATION

Front and rear axles

The front and rear axle dust boots **1** must be checked for holes or wear before operating. If any damage is found, have your dealer check and repair the vehicle.

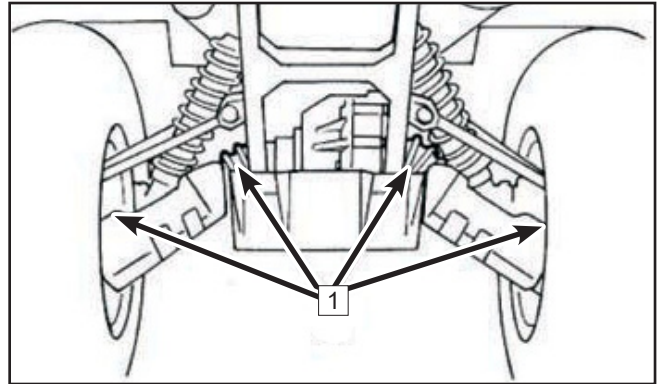
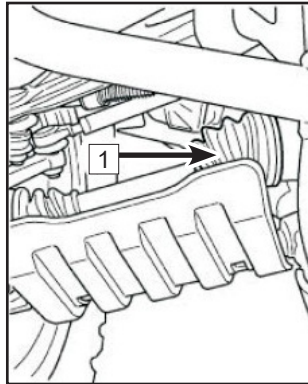
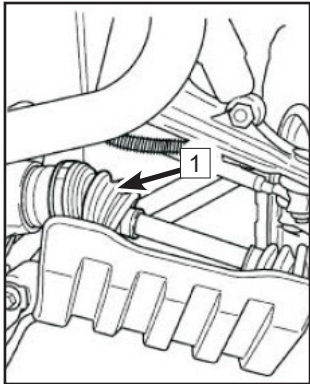

MAINTENANCE & LUBRICATION

Spark plug

The spark plug is an important engine component that is easy to inspect. The color and condition of the spark plug can indicate the condition of the engine. The ideal color on the insulator around the center electrode is a medium-to-light tan color for an engine that is being operated normally. If electrode erosion becomes excessive, or if carbon and other deposits are excessive, you should replace the spark plug with the specified plug.

Periodically remove and inspect the spark plug for heat damage and deposits that will cause the spark plug to break down and erode. Do not attempt to diagnose spark plug color or engine problems yourself. Instead, take the vehicle to your dealer for service.

Inspection

1. Remove the left side panel:
 - Remove the seat
 - Remove the 2 bottom screws from the left inner fender
 - Remove the bottom bolt from the side panel
 - Pull the back of the side panel away
 - Rotate the front of the side panel up and away from the body
2. Remove the spark plug cap 1.

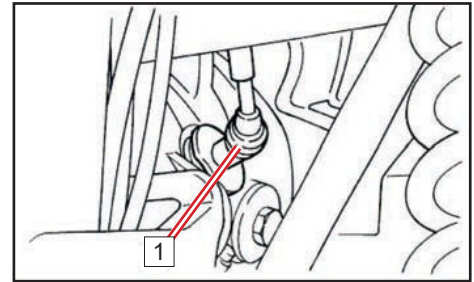

MAINTENANCE & LUBRICATION

- Use the spark plug socket and wrench **2** from the tool kit to remove the spark plug.
- Check the spark plug gap (A) using a thickness gauge. Adjust the gap if necessary.

NOTE

Specified spark plug: DCPR8E (NGK)

Spark plug gap: 0.035 in. ~ 0.045 in. (0.8 mm ~ 0.9 mm)

- Clean the gasket surface. Wipe off any grime from the threads.
- Install spark plug and tighten to specified torque.

NOTE

- Spark plug torque: 14.8 ft-lb (20 N•m). If a torque wrench is not available when you are installing a spark plug, a good estimate of the correct torque is 1/4 to 1/2 turn past finger tight.
- Install the spark plug cap.
- Install the side panel.

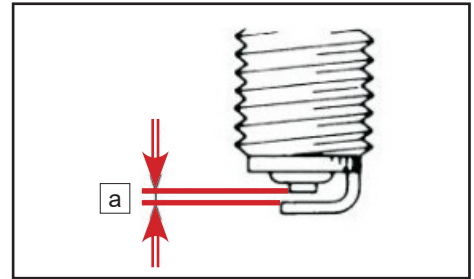
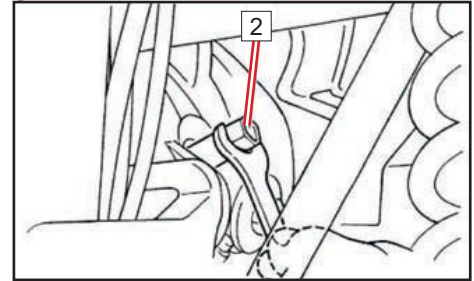

MAINTENANCE & LUBRICATION

Spark plug removal to expel water from the engine

If water has been ingested into the engine, it is important to remove the water as soon as possible by removing the spark plug and using the starter system to rotate the engine for a short period to expel water out of the cylinder. Verify that the air box has been drained of water before attempting to expel water.

CAUTION

Major engine damage can result if the vehicle if water is ingested into the engine. Have the vehicle serviced by your dealer promptly if your vehicle becomes immersed or stalls in water that exceeds the footrest level. It is important to contact your dealer for service before starting the engine if water has been ingested. Water inside the engine can cause a 'hydraulic lock' effect that can damage the starter and engine components. The engine oil should be checked for water contamination. Drain and refill with new engine oil if water is found in the crankcase.

MAINTENANCE & LUBRICATION

Air filter

Always check and change the engine oil at the intervals outlined in the Maintenance Schedule. The air filter element should be cleaned more often if the machine is operated in extremely dusty or wet areas. There is a check hose **1** at the bottom of the air filter housing. If dust or water can be viewed in this hose, empty the hose and clean the air filter housing thoroughly. If the vehicle was submerged, please contact your local dealer to check for water inside the engine crankcase.

Air filter housing inspection

There is a check hose **1** at the bottom of the air filter housing. If dust or water can be viewed in this hose, empty the hose and clean the air filter housing thoroughly. If the vehicle was submerged, please contact your local dealer to check for water inside the engine crankcase.

Air filter maintenance

1. Remove the seat.
2. Remove the cover spring clips **2**, the cover screws **3**, and then remove the filter housing cover.

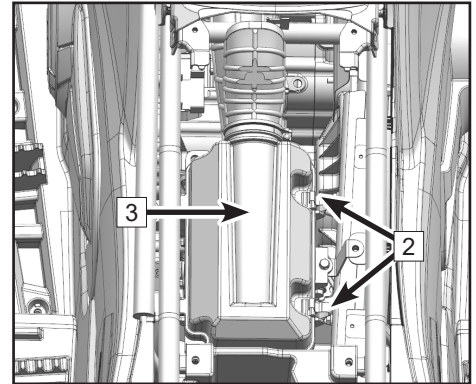
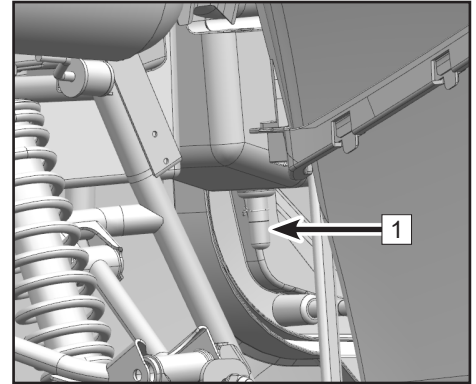

MAINTENANCE & LUBRICATION

- Loosen the air filter clamp **4** and remove the air filter **5**.
- Remove the foam pre-filter **6** from the air filter.
- Wash the foam pre-filter gently with soap and water, and allow it to completely dry.
- Inspect the paper air filter and verify it is okay to reinstall. Softly brush off accumulated dust if necessary. Install a new filter as necessary.

NOTE

Do not wash paper air filters, or use compressed air to clean the filter media.

- Install the pre-filter onto the air filter. Apply a thin film of lubricant on the inside diameter of the air filter rubber seal.
- Install the air filter and clamp onto the air filter housing inlet. Tighten the clamp securely.
- Reinstall the air filter housing cover and spring clips. Verify the cover is installed correctly and is sealing properly.

NOTE

The air filter element should be cleaned every 50 hours, It should be cleaned and lubricate more often if the machine is operated in extremely dusty areas. Each time air filter element maintenance is performed, check the air inlet to the air filter box for obstructions. Check the air filter element rubber joint to the throttle body and manifold fittings for an airtight seal. Tighten all fittings securely to avoid the possibility of unfiltered air entering the engine.

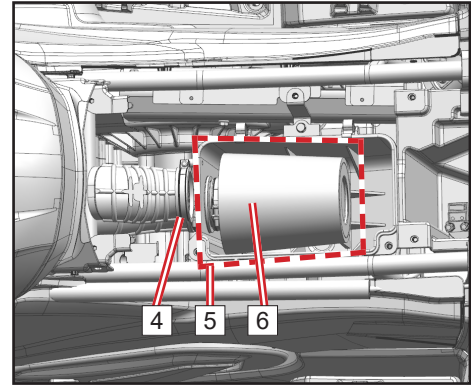

MAINTENANCE & LUBRICATION

Drying the air filter housing after submersion

If water has been ingested into the air filter housing, Drain the air filter housing, remove the air filter, and thoroughly dry the components. Do not use compressed air. Contact your dealer if vehicle performance issues exist.

CAUTION

Do not operate the engine without an air filter element. Unfiltered air will enter into the engine and cause engine wear and damage. Driving without an air filter will also decrease performance and can lead to engine overheating.

CAUTION

Major engine damage can result if the vehicle if water has been ingested into the air filter housing, and engine. Have the vehicle serviced by your dealer promptly if your vehicle becomes immersed or stalls in water that exceeds the footrest level. It is important to contact your dealer for service before starting the engine, as water may have been ingested in the air box and engine.

MAINTENANCE & LUBRICATION

Exhaust spark arrester

Clean carbon deposits from the spark arrester while the muffler and exhaust are in normal air temperature.

1. Remove the fasteners **1**.
2. Tap the tailpipe lightly to loosen it and remove the spark arrester **2** from the muffler.
3. Use a wire brush to remove any carbon deposits from the spark arrester portion of the tailpipe **3**.
4. Insert the tailpipe into the muffler and align the bolt holes.
5. Install and torque the fasteners to 7.3 ft-lb. (10 N•m).

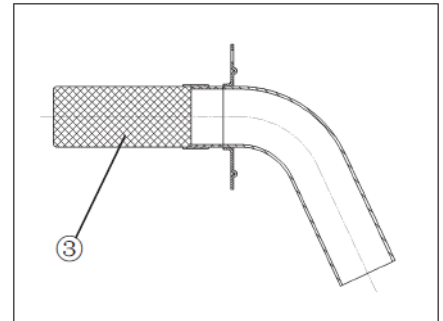
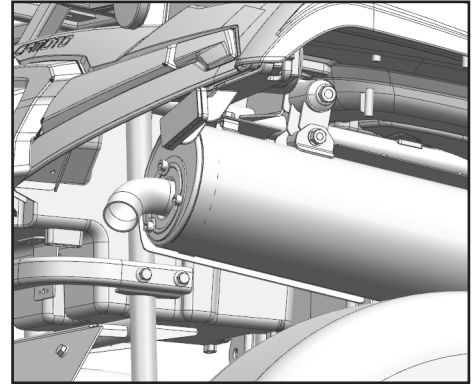

MAINTENANCE & LUBRICATION

Throttle body adjustment

The throttle body is a vital part of the engine and requires very sophisticated adjustment. Most adjusting should be left to your dealer who has the professional knowledge and experience to do so. However, the idling speed may be performed by the owner as a part of the usual maintenance routine. The throttle body was set at the factory after many tests. If the settings are disturbed by someone without sufficient technical knowledge, poor engine performance and damage may result. Check idle for stability and contact your dealer for service if necessary.

Engine idel adjustment:

WARNING

this vehicle is equipment with EFI system, and no need to adjust idle, or performance will be affected. Contact your dealer in case abnormal idle.

NOTE

Engine idle: 1,500r/min±150r/min (Heated engine)

●**Engine air inlet/outlet valve clearance adjustment**

The correct valve clearance changes with use, resulting in improper fuel/air supply or engine noise. To prevent this, the valve clearance must be adjusted regularly. This adjustment however, should be left to a professional service technician.

MAINTENANCE & LUBRICATION

Brakes

Front brake pad inspection

Inspect the front brake pads and discs for damage and wear. If the pad thickness **A** is less than 0.059 in. (1.5mm) or the disc thickness **B** is less than 0.118 in. (3.0mm), have your dealer replace them. Replacement of brake components requires professional knowledge. These procedures should be performed by your dealer.

NOTE

Wheels must be removed to check brake pads.

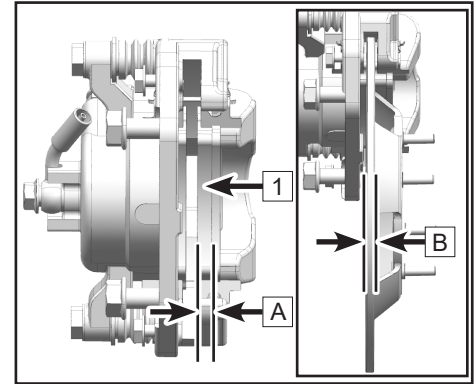

⚠ CAUTION

After servicing:

- Make sure the brakes operate smoothly and that the lever free play is correct.
- Make sure the brakes do not drag and the brake operation is not spongy.
- All air is bled from the brake system.

MAINTENANCE & LUBRICATION

Rear brake pad inspection

Inspect the brake pads and rear brake discs for damage and wear. If the pad thickness “a” is less than 1.5mm or the disc thickness “b” is less than 4.0mm, then have your dealer replace them. Replacement of brake components requires professional knowledge. These procedures should be performed by your dealer.

CAUTION

After servicing:

- Make sure the brakes operate smoothly and that the lever free play is correct.
- Make sure the brakes do not drag and the brake operation is not spongy.
- All air is bled from the brake system.

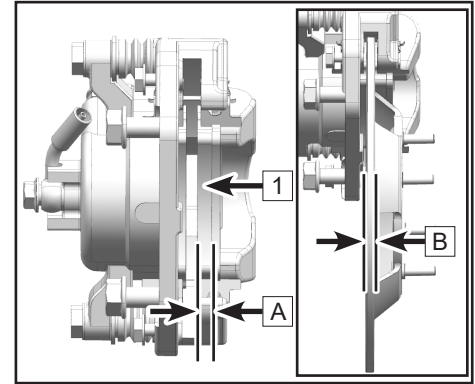

MAINTENANCE & LUBRICATION

Brake fluid level inspection

Before riding, check that the brake fluid levels are above the lower mark and replenish whenever necessary. Insufficient brake fluid may let air enter the brake system, possibly causing the brakes to become ineffective. The front brake fluid master cylinder reservoir level **A** is located on the right handlebar. The rear brake fluid master cylinder reservoir **B** is under the front rack access panel.

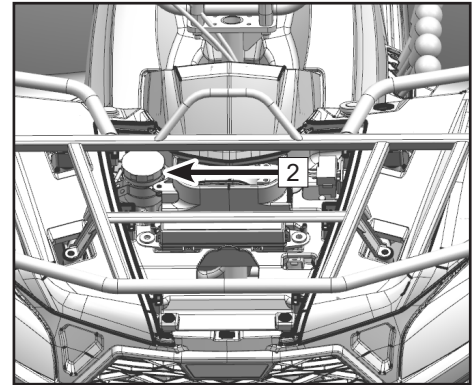
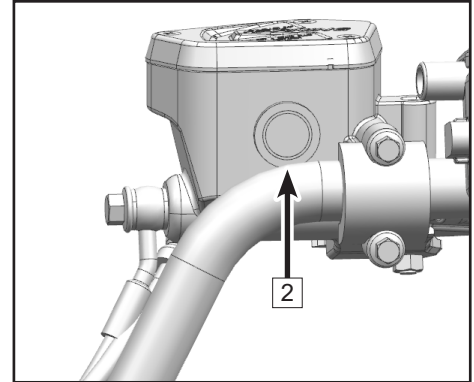

MAINTENANCE & LUBRICATION

Observe these precautions:

1. When checking the fluid level, make sure the top of the master cylinder reservoir is level by turning the handlebars.
2. Use only the designated quality brake fluid. Otherwise, the rubber seals may deteriorate, causing leakage and poor brake performance.
3. Recommended brake fluid: DOT 4.
4. Refill with the same type of brake fluid. Mixing fluids may result in a harmful chemical reaction and lead to poor brake performance.
5. Be careful that water does not enter the master cylinder reservoir when refilling. Water will significantly lower the boiling point of the fluid and may result in vapor lock.
6. Brake fluid may deteriorate painted surfaces or plastic parts. Always clean up spilled fluid immediately.
7. Have your dealer check the cause if the brake fluid level goes down.

Brake fluid change

Complete fluid replacement should be done only by trained service personnel. Have your dealer replace the following components during periodic maintenance or when they are damaged or leaking.

Replace the oil seals every two years

Replace the brake hoses every four years.

MAINTENANCE & LUBRICATION

Front brake lever freeplay^a

The front brake lever should have a free play at the lever end. If not, contact your dealer to check the brake system.

⚠ DANGER(After servicing):

Make sure the brakes operate smoothly and that the free play is correct;

- Make sure the brakes do not drag. Make sure the brakes are not spongy.
- All air must be bled from the brake system. Replacement of brake components requires professional knowledge. These procedures should be performed by your dealer.

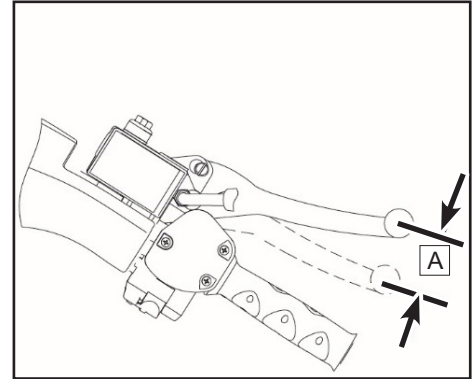

MAINTENANCE & LUBRICATION

Foot brake pedal hight adjustment

NOTE

Inspect the rear brake pad thickness before adjusting the foot brake.

The top of the brake pedal **B** should be positioned 70mm ~ 80mm above the top of the footrest. If not,ask your dealer to adjust it.

⚠ DANGER

After servicing:

- Make sure the brakes operate smoothly and that the free play is correct.
- Make sure the brakes do not drag;
- All air must be bled from the brake system.

Replacement of brake components requires professional knowledge. These procedures should be performed by your dealer.

]

Brake light switch

The rear brake light switch, which is activated by the foot brake pedal and front brake levers, is properly adjusted when the brake light comes on just before braking takes effect. Check if the switch assembly and the cables are properly fixed in case of brake light failure.

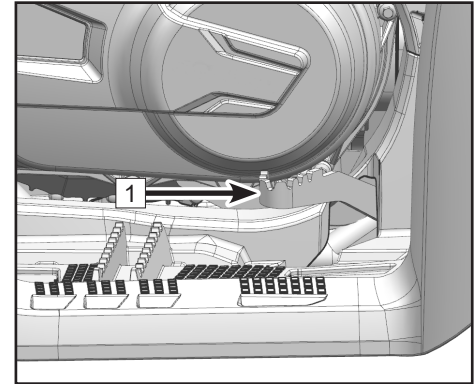

MAINTENANCE & LUBRICATION

Suspension

Front suspension lubrication

The front suspension of the vehicle contains components that require no maintenance or lubrication. Ensure the components are cleaned regularly, and are not loose or damaged before operating the vehicle.

Rear suspension lubrication

Lubricate the upper and lower pivots of the rear axles:

1. Remove the rear wheels **1**.
2. Add grease into the grease nipples **2** at the upper and lower pivots with a grease gun.
3. Reinstall the rear wheels. Torque the fasteners to specification.

NOTE

Recommended lubricant: All Season Grease

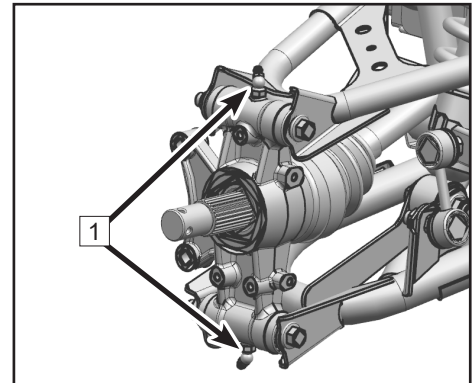
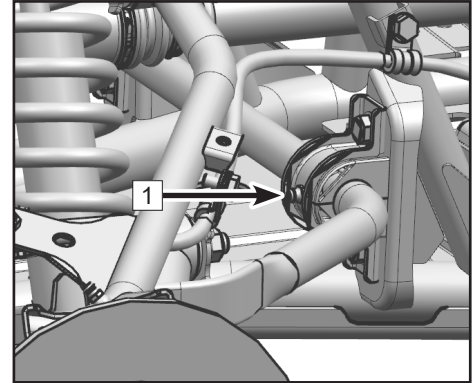

MAINTENANCE & LUBRICATION

Front and rear suspension adjustment

The front and rear suspension spring preload can be adjusted to suit the rider's weight and riding conditions.

NOTE

When adjusting the rear shock absorbers, the rear wheels need to be removed.

Adjust the spring preload as follows.

To increase the spring preload, turn the adjusting ring **1** in direction **a**.

To decrease the spring preload, turn the adjusting ring **1** in direction **b**.

Standard preload position: **C**

A- Minimum (soft)

E- Maximum (hard)

NOTE

A special wrench **2** (if not supplied in tool kit) can be obtained at a dealer to make this adjustment.

Always adjust the shock absorbers on the left and right sides to the same setting.

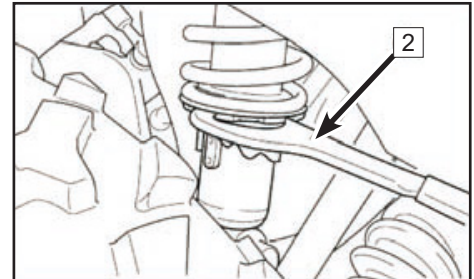
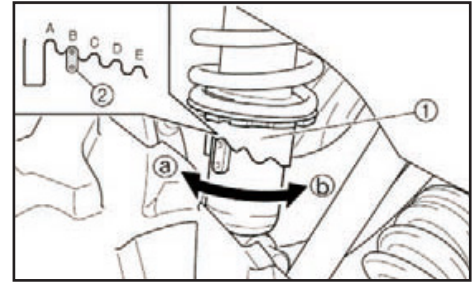

MAINTENANCE & LUBRICATION

Wheels

Wheel removal

1. Loosen the wheel nuts.
2. Elevate the Vehicle and place a suitable stand under the frame.
3. Remove the nuts from the wheel.
4. Remove the wheel.

Wheel installation:

1. Install the wheel and the nuts.
2. Lower the Vehicle so that the wheel is on the ground.
3. Tighten the wheel nuts to the specified torque.

NOTE

- Tapered nuts are used for both the front and rear wheels. Install the nut with its tapered side towards the wheel
- The arrow mark on the tire must point toward the rotating direction of the wheel.

Wheel nut torque: Front: 70 N•m ~ 80 N•m ;

Rear: 70 N•m ~ 80 N•m .

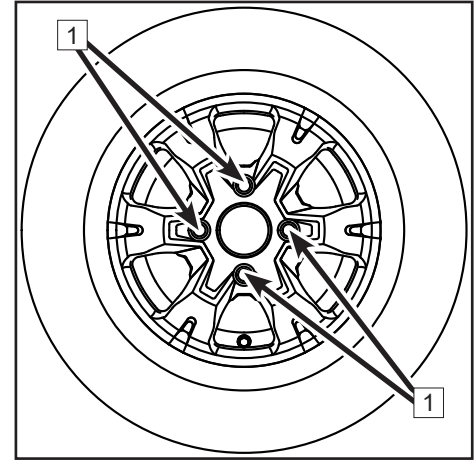

MAINTENANCE & LUBRICATION

Wheels

Tire pressure

Inspect the tire pressure before operation:

Front: 8.0 psi (56 kPa)

Rear: 6.0 psi (42 kPa)

Wheel Bolt Pattern: 4x110mm

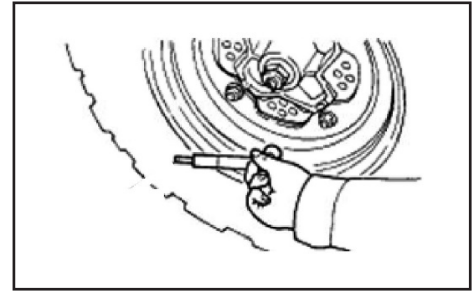

Tread depth

Inspect the tread depth regularly and replace the tires if the minimum tread depth is less than:

Minimum tread depth: 3/32 in. (3.0 mm)

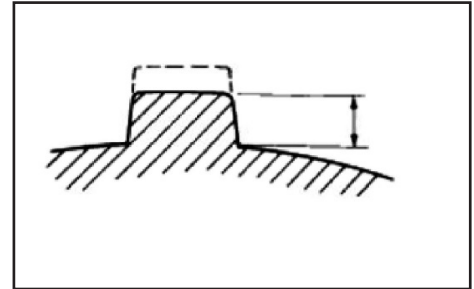

MAINTENANCE & LUBRICATION

Battery

This vehicle is equipped with a 12 volt / 30 Amp hour, sealed low-maintenance battery, which is located under the seat. Therefore, it is not necessary to check the electrolyte or add distilled water to the battery. If the battery seems to have discharged, consult your dealer. Verify that the battery connections are clean and secured during routine maintenance.

Battery maintenance guidelines:

- If the vehicle will not be used for a month or longer, remove the battery and store it in a cool, dry place. Completely recharge the battery before re-installation.
- A special battery charger (constant low voltage/ampere) is required for recharging low maintenance batteries. Using a conventional battery charger may shorten the battery life.
- Always make sure the cable connections are the correct polarity when reinstalling the battery. RED ('+' positive) / Black ('-' negative). Always disconnect the RED ('+' positive) cable last during removal, and reconnect it first during installation.
- Corroded battery connections can be cleaned with a mixture of baking soda and water.

WARNING

Avoid contact with skin, eyes or clothing, and always shield eyes when working near batteries. Keep out of reach of children. Keep batteries away from sparks, flames, cigarettes or other sources of ignition. Ventilate the area when charging or using in a closed space.

Battery acid antidote:

EXTERNAL: Flush with water.

INTERNAL: Get prompt medical attention.

EYES: Flush with water for 15 minutes and get prompt medical attention.

MAINTENANCE & LUBRICATION

Lights

Headlight bulb replacement

NOTE:

For LED headlight: LED lights cannot be repaired if damaged or failed. Please have your dealer replace the entire assembly if the LED light is damaged or failed.

For halogen headlight: Halogen lights can be repaired if damaged or failed. Please have your dealer repair or replace with new one.

(*Vehicles equipped with LED headlight or halogen headlight as standard equipment according to selected market)

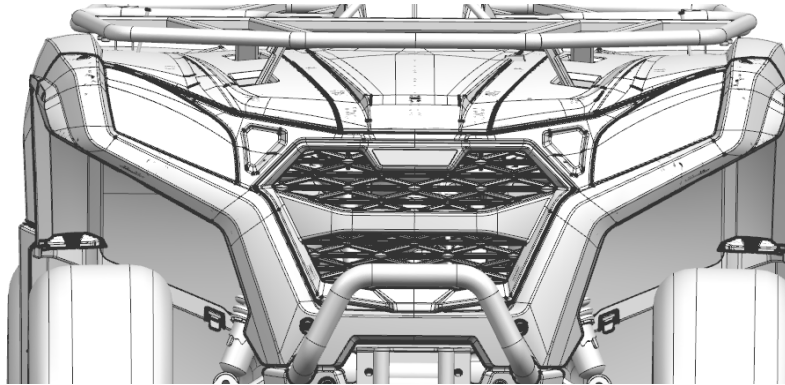

MAINTENANCE & LUBRICATION

Headlight beam adjustment

⚠️ WARNING

It is advisable to have your dealer make this adjustment. Turn the adjusting screws can raise or lower the beam.

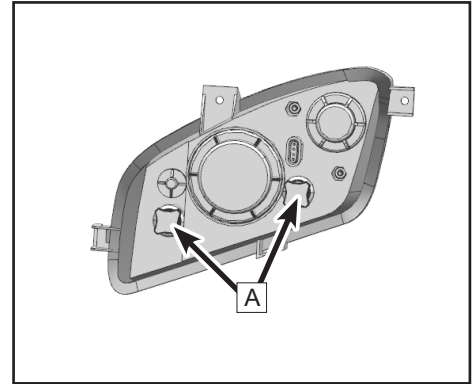

Tail / brake light replacement:

Tail/brake light cannot be replaced separately. Replace the whole light if necessary.



MAINTENANCE & LUBRICATION

Fuse and Relay replacement

1. Relay / Fuse box **1** is located under the front access cover.
2. If a fuse is blown, turn off the main switch and install a new fuse of the specified amperage. Test by turning on main power and switches. If the fuse immediately blows again, consult your dealer.

CAUTION

Always use a fuse of the specified rating.

Never use conductive material in place of the proper fuse.

Turn off the main switch when inspecting or replacing the fuse.

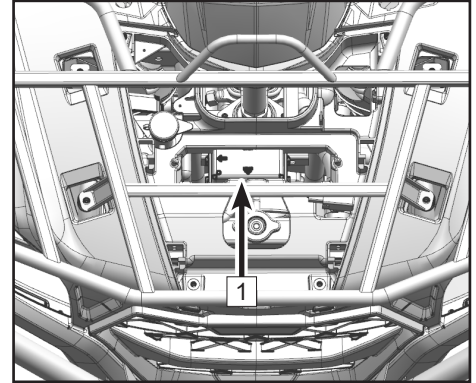

MAINTENANCE & LUBRICATION

WARNING

If your vehicle becomes immersed, major engine damage can result if the machine is not thoroughly inspected. Take the vehicle to your dealer before starting the engine. For example, if engine is not properly handled after immersion, starting will damage the engine.

Fuel Evaporation System (EVAP) (If equipped)

Your vehicle contains a fuel evaporation system (EVAP) that prevents fuel vapors from entering the atmosphere from the fuel tank and fuel system. Never modify any part of this system, which will violate fuel evaporation emission regulations.

During routine maintenance, visually inspect all connections for leaks and blockage, and inspect the hoses for kinks or damage.

No other maintenance is necessary. Contact your dealer if repair is required.

NOTE: Information applies only to vehicles equipped with a fuel evaporation system.

CLEANING & STORAGE

Cleaning and Storage

Washing the vehicle

Keeping your vehicle clean will not only improve its appearance, but it can also extend the life of various components. With a few precautions, your vehicle can be cleaned much like an automobile:

- The best and safest way to clean your vehicle is with a garden hose and a pail of mild soap and water. Harsh detergents may deteriorate rubber components.
- Use a professional type washing mitt, cleaning the upper body first and the lower parts last.
- Pay special attention that the cooling system radiator and axle boots are thoroughly cleaned of all dirt and debris.
- Rinse with water frequently and dry the vehicle with a chamois to prevent water spots.
- Lubricate all pivot points immediately after washing.
- Allow the engine to run for a while to evaporate any water that may have entered the engine air intake or exhaust system.

We do not recommend the use of a high pressure type car wash system for washing your vehicle, as water can be forced past seals. If a high pressure system is used, exercise extreme care to avoid water damage to the decals, wheel bearings, transmission seals, body panels, brakes, warning labels, air filter intake system and electrical system. Ensure water is not allowed to enter into the air filter housing. If warning and safety labels are damaged, contact your dealer for a replacement.

CLEANING & STORAGE

Waxing the Vehicle

Your Vehicle can be waxed with any non-abrasive automotive paste wax. Avoid the use of harsh cleaners since they can scratch the body finish.

CAUTION

Certain products,including insect repellants and chemicals,will damage plastic surfaces. Use caution when using these products near plastic surfaces.

Perform Repairs

Make necessary repairs to your vehicle before storing to prevent further damage the next time you operate it.

Check the Tires

Inspect the tire treads and overall condition. Set the tires to the specified air pressure.

Oil and Filter

Warm the engine, then stop the engine and change the oil and filter.

Air filter/ Air box

Inspect and clean or replace air filter. Clean the air box and the sediment tube.

CLEANING & STORAGE

Check Fluid Levels

Inspect the following fluid levels and change if necessary:

- Front gear case
- Rear gear case
- Brake fluid (change every two years or as required if fluid looks dark or contaminated)
- Coolant (change every two years or as required if coolant looks contaminated)
- Fuel Level (add fuel stabilizer according to the product label directions)

Stabilize the Fuel

Fill the fuel tank with fresh fuel that has been treated with fuel stabilizer according to the product label directions. Do not allow untreated fuel to remain in the tank longer than 30 days, as the fuel begins to degrade and can cause damage to the fuel system components.

Battery Storage

- Remove the battery from the vehicle and ensure that it is fully charged before placing it in storage. Protect the battery from freezing temperatures, which can damage the battery.

Lubricate

Inspect all cables and lubricate with cable lubricant according to the product label directions. Grease the vehicle lubricating points with all season grease.

CLEANING & STORAGE

Fog the Engine

- Tilt the cargo box to access the spark plug(s).
- Remove the spark plug(s), rotate the piston to the bottom of its stroke, and pour approximately 2.0 oz. (15mL~20mL) of engine oil into the opening.

NOTE:

Do this carefully! If you miss the spark plug hole, oil will drain from the spark plug cavity, and appear to be an oil leak. To access the spark plug hole, use a section of clean hose and a small plastic squeeze bottle filled with the pre-measured amount of oil.

- Reinstall the spark plug(s). Torque the spark plug to specification.
- Turn engine over several times slowly. Oil will be forced in and around the piston, piston rings and the
- Cylinder will be coated with a protective film of fresh oil.
- Reinstall the spark plug(s), cap(s), and side panel.

NOTE:

Starting the engine during the storage period will disturb the protective film created by fogging. Corrosion could occur. Never start the engine during the storage period.

CLEANING & STORAGE

Storage Area And Covering

Support the vehicle with stands under the frame with the tires 30mm~40mm (1/2in) off the ground. Be sure the storage area is well ventilated, and cover the machine with an approved cover.

NOTE:

Do not use covers made of plastic or coated materials. They do not allow enough ventilation to prevent condensation, and may promote corrosion and oxidation.

Transporting the Vehicle

Follow these procedures when transporting the vehicle:

- Turn off the engine and remove the key to prevent loss during transporting.
- Place the gear selector into any position except the parking position, and block the front and rear wheels to prevent the vehicle from moving.
- Ensure the fuel cap is installed correctly and secure.
- Ensure the seat is installed correctly and secure.
- Secure the front and rear vehicle frame to the transporting device. This will prevent the vehicle from sliding or moving during transport.

CAUTION

Never transport with the gear selector in the parking position. Damage to the engine and transmission may result.

CLEANING & STORAGE

Vehicle Issue Diagnosis

This section is intended to guide an average owner to simple items that could cause operating problems. Diagnosis of vehicle issues may require the experience of a dealership technician. Please contact your dealer if a solution is not apparent.

Engine doesn't turn over

Possible Cause	Solution
Blown fuse	Reset or replace the fuse
Low battery voltage	Recharge battery to 12.8 Vdc – Confirm battery state of health
Loose battery connections	Check all connections and tighten if necessary
Loose starter system electrical connections	Check all connections and tighten if necessary
Engine stop switch	Check function
Start circuit not complete – transmission in gear	Press foot brake or shift transmission to neutral or parking position.

Engine pings or knocks

Possible Cause	Solution
Poor quality or low octane fuel	Replace with minimum 95 octane unleaded fuel
Incorrect ignition timing.	See your dealer
Incorrect spark plug gap or heat range	Set spark plug gap to specs or replace plugs

Vehicle Issue Diagnosis

Engine stops or loses power

Possible Cause	Solution
Overheated engine	Clean radiator screen and external core; clean engine exterior; See your dealer
Out of fuel	Refuel with minimum 95 octane unleaded fuel
Kinked or plugged fuel tank vent line	Inspect and replace; See your dealer
Water present in fuel	Replace with new fuel
Fouled or defective spark plugs	Inspect and clean or replace spark plug
Worn or defective spark plug wires	See your dealer
Incorrect spark plug gap or heat range	Set gap to specs or replace plug
Loose ignition connections	Check all connections and tighten
Low battery voltage	Recharge battery to 12.8 Vdc; check charging system – Confirm battery health
Clogged air filter	Inspect and replace as necessary
Reverse speed limiter malfunction	See your dealer
Electronic throttle control malfunction	See your dealer
Other mechanical failure	See your dealer

Vehicle Issue Diagnosis

Engine turns over, Fails to start

Possible Cause	Solution
Out of Fuel	Refuel
Clogged fuel filter	Inspect and replace as necessary
Water is present in fuel	Replace with 95 minimum octane unleaded fuel
Fuel pump is inoperative	Inspect pump and fuse; Replace as necessary
Old or non-recommended fuel	Replace with 95 minimum octane unleaded fuel
Fouled or defective spark plug(s)	Inspect spark plug(s), replace if necessary
No spark to spark plug	Inspect spark plug(s) , verify stop switch is on
Crankcase filled with water or fuel	Immediately see your dealer
Clogged air filter	Inspect and replace as necessary; Replace spark plugs as necessary
Clogged fuel injector	See your dealer
Low battery voltage	Recharge battery to 12.8 Vdc – Confirm battery health
Mechanical failure	See your dealer

Vehicle Issue Diagnosis

Engine backfires

Possible Cause	Solution
Weak spark from spark plugs	Inspect and replace spark plugs as necessary
Incorrect spark plug gap or heat range	Set gap to specs or replace plugs
Old or non-recommended fuel	Replace with minimum 95 octane unleaded fuel
Incorrectly installed spark plug wires	See your dealer
Incorrect ignition timing	See your dealer
Mechanical failure	See your dealer
Speed limiter malfunction	See your dealer

Engine runs irregularly, stalls or misfires

Possible Cause	Solution
Fouled or defective spark plugs	Inspect and replace spark plugs as necessary
Worn or defective spark plug wires	See your dealer
Incorrect spark plug gap or heat range	Set gap to specs or replace plugs
Loose ignition connections	Check all connections and tighten
Water present in fuel	Replace with new fuel
Low battery voltage	Recharge battery to 12.8 Vdc; Check charging system
Kinked or plugged fuel tank vent line	Inspect and replace
Incorrect fuel	Replace with 95 minimum octane unleaded fuel
Clogged air filter	Inspect and replace as necessary; Replace spark plugs as necessary

Vehicle Issue Diagnosis

Possible Cause	Solution
Reverse speed limiter malfunction	See your dealer
Electronic throttle control malfunction	See your dealer
Other mechanical failure	See your dealer
Possible Lean or Rich fuel mixture	See your dealer
Low or contaminated fuel	Add or change fuel, clean the fuel system
Low octane fuel	Replace with minimum 95 octane unleaded fuel
Clogged fuel filter	Replace filter
Fuel is very high octane	Replace with minimum 95 octane unleaded fuel

Vehicle Issue Diagnosis

Engine Backfires

Possible Cause	Solution
Weak spark from spark plugs	Inspect, clean and/or replace spark plugs
Incorrect spark plug gap or heat range	Set gap to specs or replace plugs
Old or non-recommended fuel	Replace with new fuel
Incorrectly installed spark plug wires	See your dealer
Incorrect ignition timing	See your dealer
Mechanical failure	See your dealer

Engine Runs Irregularly, Stalls or Misfires

Possible Cause	Solution
Fouled or defective spark plugs	Inspect, clean and/or replace spark plugs
Worn or defective spark plug wires	See your dealer
Incorrect spark plug gap or heat range	Set gap to specs or replace plugs
Loose ignition connections	Check all connections and tighten
Water present in fuel	Replace with new fuel
Low battery voltage	Recharge battery to 12.8 Vdc

Vehicle Issue Diagnosis

Possible Cause	Solution
Reverse speed limiter malfunction	See your dealer
Electronic throttle control malfunction	See your dealer
Other mechanical failure	See your dealer
Possible Lean or Rich fuel mixture	See your dealer
Low or contaminated fuel	Add or change fuel, clean the fuel system
Low octane fuel	Replace with minimum 95 octane unleaded fuel
Clogged fuel filter	Replace filter
Fuel is very high octane	Replace with minimum 95 octane unleaded fuel

Vehicle Issue Diagnosis

EFI Malfunction Indicator Light

The Electronic Fuel Injection system on your vehicle contains a self-diagnostic feature that will illuminate the malfunction indicator light (MIL) if it detects a problem. When this indicator is on,

Please contact your dealer for diagnosing. Your dealer has the EFI tool required to diagnose, repair and clear trouble codes.

During normal operation, the EFI indicator will be off.

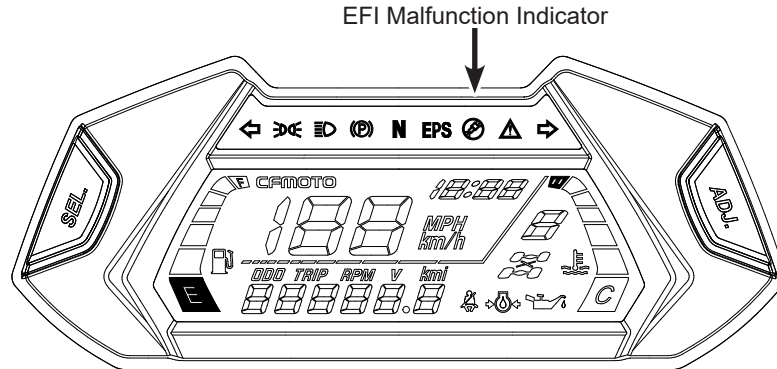

Vehicle Issue Diagnosis

EPS Malfunction Indicator Light

The Electronic Power Steering system on your vehicle contains a self-diagnostic feature that will illuminate the malfunction indicator light (MIL) if it detects a problem, when this indicator flashes, please contact your dealer. In normal operation, the EPS indicator will be on after the ignition switch is turned to ON, but EPS will not work. When the engine is started, the EPS indicator will be off and the EPS starts to function.

Each trouble code consists of 2 digits, denoted by the times of long flash and short flash of EPS MIL indicator. If there is a failure, the EPS indicator will start to flash. Do NOT switch off the machine. Check the flash sequence of EPS indicator. Write down the flash sequence and contact your dealer for diagnosis. Your dealer has the special tool required to diagnose, repair and clear trouble codes. Any codes will disappear once the problem has been diagnosed and repaired by your dealer.

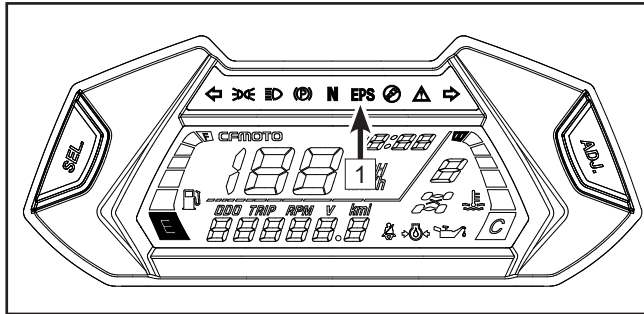

1 EPS Indicator

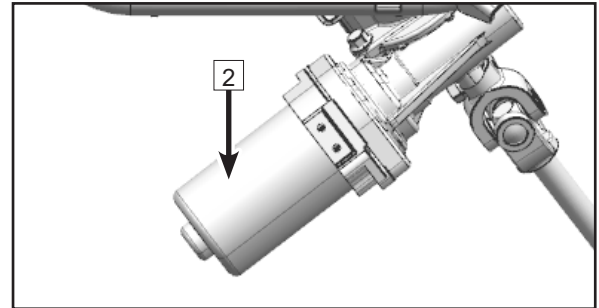

2 EPS Assembly

Vehicle Issue Diagnosis

EPS Malfunction Indicator

Times of long flash represent the tens digit;

Times of short flash represent the single digit;

Duration of long flash: 2 sec.

Duration of short flash: 1 sec.

Flash interval: 1 sec.

The flash cycle will repeat after EPS MIL indicator light turns off for 3 seconds

Stop operating the vehicle and contact your dealer immediately if the EPS system MIL is flashing or there is a loss of steering assist with the engine running.

Vehicle Issue Diagnosis

EPS fault diagnosis and solution

No	Failure Phenomenon	Probable Reason	Troubleshooting
1	Steering without assistance	<ol style="list-style-type: none"> 1.Connectors of wire is bad contact 2.The fuse blew out 3.Relay damage 4.The controller, motor or sensor is damaged 	<ol style="list-style-type: none"> 1.Check whether wire connectors are fully inserted 2.Replace the fuse(30A) 3.Replace the relay 4.Contact with suppliers and replace it
2	Power don't weighs the same for left and right	<ol style="list-style-type: none"> 1.The median output voltage have deviation 2.Controller, motor or sensor is damaged 	<ol style="list-style-type: none"> 1.Disconnect motor connectors, loosen the sensor adjustment screw, adjust the sensor position to keep the voltage in $1.65V \pm 0.05V$ 2.Contact with suppliers and replace it
3	When system is on, the steering wheel swings on both sides	<ol style="list-style-type: none"> 1.Motor is mounted backwards 2.Controller or sensor is damaged 	<ol style="list-style-type: none"> 1.Exchange the position of (thick line) red line and black line at the motor terminal 2.Contact with suppliers and replace it
4	Steering becomes heavy	<ol style="list-style-type: none"> 1.Battery have power loss 2.Motor damage (power reduction) 3.air pressure of the tires (front) is insufficient. 	<ol style="list-style-type: none"> 1.Charge 2.Contact with suppliers and replace it 3.Inflate tires
5	System has noise	<ol style="list-style-type: none"> 1.Motor damage 2.Gap of lower steering shaft assembly or mechanical steering assembly is too large 3.Installation of lower steering shaft assembly or mechanical steering assembly is unfirm 	<ol style="list-style-type: none"> 1.Replace 2.Replace 3.Check whether the installation screw is tight, reinforcement

DECLARATION

Declaration

Declaration of Drivers exposure to noise level

The undersigned :Lai Min jie ,General Manager

Company name and address of the manufacturer:

ZHEJIANG CFMOTO POWER CO.,LTD.

No.116,Wuzhou Road,Yuhang Economic Development Zone,Hangzhou,311100,

Zhejiang Province P.R.China

Make(trade name of the manufacturer): GOES

Variant(s)	Variant(s)	Commercial name(s) (if available)	Category, subcategory and speed index of the vehicle	The Drivers exposure to noise level result (limit: 86dB(A))
CF400ATR-4S	A	TERROX 400S	T3b	85.6dB(A)
	B	TERROX 400S	T3a	85.3dB(A)
CF400ATR-4L	A	TERROX 400L	T3b	85.6dB(A)
	B	TERROX 400L	T3a	85.3dB(A)
CF500ATR-11S	A	TERROX 500S	T3b	85.7dB(A)
	B	TERROX 500S	T3a	85.3dB(A)
CF500ATR-11L	A	TERROX 500L	T3b	85.7dB(A)
	B	TERROX 500L	T3a	85.3dB(A)

test method 2 of Annex XIII to EU 1322/2014

DECLARATION

Declaration of Vibration declaration

Driver mass		aws m/s ²	CF400ATR-4S/ CF500ATR-11S	CF400ATR-4L/ CF500ATR-11L	Requirement
59kg±1kg	T1	Test run1	1.23	1.22	Deviation<10% between test run 1/2 and Arithmetic mean,aws<1.25m/s ²
	T2	Test run2	1.22	1.21	
	A	Arithmetic mean	1.23	1.22	
98kg±5kg	T1	Test run1	1.14	1.09	Deviation<10% between test run 1/2 and Arithmetic mean,aws<1.25m/s ²
	T2	Test run2	1.13	1.10	
	A	Arithmetic mean	1.14	1.10	

aws:rms value of the weighted seat vibration acceleration measured during a standard roadway test

G GOES